

User Manual

Galaxis Showtechnik

PYROTEC

L-Flame Pump Station

Firmware V2.15a

L-Flame Flame Head

Firmware V2.23

Revision date: February 17th 2026

Pump Station Batch No.: EULPS10099, EULPS10100, EULPS10101
Flame Head Batch No.: EULFH10099, EULFH10100, EULFH10101

Table of contents

1	Introduction	6
1.1	Safety instructions	6
1.2	Requirements the operator has to fulfill and necessary qualification	7
1.3	General safety instructions when using the L-Flame and useful additional information regarding the technical status	8
1.4	Application fields and intended use	16
1.5	Required approvals	16
2	General warnings and notes regarding the Pump Station	17
3	General warnings and notes regarding the Flame Head	19
4	Illustration and description of indicators and control elements	22
4.1	Pump Station	22
4.2	Flame Head	24
4.3	Carrying handles at the Pump Station	25
5	Safety distances	26
6	The LED indicators at the Pump Station	27
6.1	The LED 'Operation' (blue)	27
6.2	The LED 'Charging' (green)	27
6.3	The LED 'Low Battery' (red)	27
6.4	The LED 'Fault' (red)	27
7	The LED indicators at the Flame Head	28
7.1	The LED 'Operation' (blue)	28
7.2	The LED 'Flame' (yellow)	28
7.3	The LED 'Low Battery'	28
7.4	The LED 'Fault' (red)	28
8	Inputs, pin assignments and usage of electrical connectors	29
8.1	The emergency off input (E-Stop)	29
8.2	The DMX512 input and output	29
8.3	Control via DMX512	30
8.4	Charging of the Pump Station	31
9	Approved fuels and their advantages and disadvantages	32
9.1	Isopropanol, also known as IPA	33
9.2	Isopar L	33
9.3	Ethanol and bio-ethanol (also organic ethanol)	33
10	Additives forbidden for colored flames and other fuels	33
11	Personal protective equipment	34
12	Installation of the L-Flame system	34
13	Dismantling the L-Flame system	35
14	Tilting of the L-Flame Flame Head	35
15	Mounting on trusses or other constructions	36
16	Truss mounting plate for the L-Flame Flame Head	36
17	'Flying' the L-Flame Pump Station (mounting above the audience)	36
18	Additional requirements for fixed installations	37
19	Fuel consumption and flame heights	37
20	Operating range per battery charge	37
21	Switching on the Pump Station and meaning of the standard displays in the normal mode	37
22	Switching on the Flame Heads and safety timer	38
23	Automatic checks during startup of the Flame Head	40
23.1	The error message '#'	40
23.2	The error message 'ATTENTION! Flame Sensor ERROR'	41
23.3	The error message 'Radio Module not detected'	41
23.4	The error message 'Memory Error!'	41
23.5	The error message 'Firmware Mismatch'	41
23.6	The message 'Memory Maintenance'	41
23.7	Double assignment of DMX channels	41
24	Manual hardware checks with startup of the Flame Head	42
24.1	Checking the fuel valves for correct function	42
24.2	Checking the ignition spark generators for correct function	42
24.3	Check flame sensor	43
25	Battery monitoring and warning message 'deep discharge' after powering up the device	43
26	Measuring the fuel tank level	43

27	The menus of the L-Flame Pump Station.....	44
27.1	The main menu of the Pump Station.....	44
27.1.1	The menu item 'Language'	44
27.1.2	The menu item 'Accumulator capacity'	44
27.1.3	The query 'Call Submenu?'	45
27.1.4	The menu item 'Setpoint Value'	45
27.1.5	The menu item 'Negative Hysteresis':.....	46
27.1.6	The menu item 'Pressurize system?':.....	46
27.2	The submenu of the L-Flame Pump Station	47
27.2.1	DMX512 and RS485 Routing	47
27.2.2	The menu item 'Power Supply for Wi-DMX'	48
27.2.3	The menu item 'Acoustic Signals'	48
27.2.4	The menu item 'LCD Backlight'	48
27.2.5	The menu item 'Pressure Unit'	49
27.2.6	The menu item 'Depth Unit'	49
27.2.7	The menu item 'Volume Unit'.....	49
27.2.8	The menu item 'Pump out tank?'	49
27.2.9	The menu item 'Vent and back-flush?'	51
27.2.10	The menu item 'Start pump self-test?'	51
27.2.11	The menu item 'Leakage Monitoring in Pump Station'	53
28	The menu of the L-Flame Flame Head.....	54
28.1	The menu item 'Language'	54
28.2	The menu item 'Reboot?'	54
28.3	The menu item 'Accumulator Capacity'	55
28.4	The menu item 'Input'	55
28.5	Menu items if DMX512 has been selected as an input.....	55
28.5.1	The menu item 'Flame Channel'	56
28.5.2	The menu item 'Safety Channel'.....	56
28.6	Menu items if 'Cable (RS485 of PFC)' or 'Wireless (PFC, PFS or PFM)' has been selected as control method.....	56
28.6.1	The menu item 'RF Channel' (i.e. frequency selection).....	57
European Version (and also various other countries):	57	
Version for USA/Canada:	58	
28.6.2	The menu item 'Interfering Signal'	58
28.6.3	The menu item 'Last Range Test Result'.....	58
28.6.4	The menu item 'Device ID Number'.....	59
28.6.5	The menu item 'Determine Hazard Zone'	59
28.6.6	The menu item 'Terminal Programming'.....	60
28.6.6.1	Overview regarding the parameters of the Terminal programming.....	60
28.6.6.2	The selection menu of the Terminal programming	61
28.6.6.3	The menu item 'Terminal programming: Keep up & Exit'	61
28.6.6.4	The menu item 'Terminal programming: Edit'	61
28.6.6.5	The menu item 'Terminal programmierung: Delete'	63
28.6.7	The menu item 'Scanning Memory...'	63
28.6.8	The menu item 'Number of cues programmed'	63
28.6.9	The menu item 'Total flame duration'	63
28.6.10	The menu item 'Delay program. with T=0.0'	64
28.6.11	The menu item 'Keyboard Firing Mode'	64
28.7	The menu item 'Flame monitoring'	65
28.8	The menu item 'Number of Allowed Misfirings'	65
28.9	The menu item 'Max. Flame Duration'.....	66
28.10	The menu item 'Flame Quota'	66
28.11	The menu item 'Leakage Monitoring in Head and Hose'	67
28.12	The menu item 'Ignition Coil Monitoring'	67
28.13	The menu item '45° Tilt Switch'	68
28.14	The menu item tilt sensor selection 'S1, S2 or S3' and introduction into the tilt measurement by utilizing acceleration sensors.....	68
28.15	The menu item 'Store Pan/Tilt Angles'	70
28.16	The menu item 'Pan/Tilt Sensor Tolerance'	70
28.17	The menu item 'Acoustic Signals'.....	71
28.18	The menu item 'LCD Backlight'	71
28.19	The menu item 'Warning LED'.....	71



28.20	The menu item 'Inner Temperature'	71
28.21	The menu item 'Relative Humidity inside'.....	71
29	Operation on 5V mains adaptor.....	72
30	Enabling flame options in cable or wireless mode	72
31	Receiving mode or respectively ready to fire mode of the Flame Head.....	73
31.1	Displayed information during receiving mode or respectively ready to fire mode, that appears in all operation modes	73
31.1.1	Information which control method has been selected	73
31.1.2	Tilt switch on/off and its status.....	74
31.1.3	Flame Monitoring on/off.....	74
31.2	Display of special information and behavior of the device in the receiving mode or respectively ready to fire mode if 'Wireless (PFC, PFS or PFM)' or 'Cable (RS485 of PFC)' has been selected as control method.....	74
31.2.1	Status informationen regarding firing mode and hazard zone	74
31.2.2	Display of the device ID number.....	75
31.2.3	Display of messages.....	75
31.2.4	Programming of the System ID	76
31.2.5	Setting and loading default settings.....	76
31.2.6	The monitoring function Radio Interference	76
32	Switching off the system.....	77
33	Command 'Firing mode off'.....	78
34	Trouble shooting if error message 'Fail Safe triggered' or other error messages are being displayed:.....	78
34.1	Pump Station.....	78
34.1.1	Timeout Pump Duration (formerly error code 1):.....	78
34.1.2	Internal pressure loss! Leakage? (formerly error code 2):	79
34.1.3	Tank overfill, lower sensor (formerly error code 3):	79
34.1.4	Tank overfill, upper sensor (formerly error code 4):	80
34.1.5	Fuel in drain tray detected (formerly error code 5):.....	80
34.1.6	Emergency Off contact open (formerly error code 4):.....	81
34.2	Flame Head	81
34.2.1	Pressure loss in hose and head:	81
34.2.2	Ignition terminated, minimum pressure reached	81
34.2.3	Message 'No system pressure'.....	82
34.2.4	Message 'Ignition terminated!, Ignition Coil Failure'.....	82
34.2.5	Message 'Ignition terminated!, No flame detected'.....	82
34.2.6	Message 'Ignition terminated!, Device tilted!'	83
34.2.7	Message 'Fire Channel: XYZ, No system pressure'.....	83
35	Radio range	83
36	Radio range test	84
37	Remote access	84
38	Operating time	84
39	Performing a field strength calibration of the L-Flame Flame Head	85
40	Installation of accessories.....	86
41	De-Installation of the radio module.....	86
42	Configuration of the Advanced wireless module	86
43	Usage in rain.....	86
44	Drying agent in the L-Flame Flame Head.....	86
44.1	General information	86
44.2	Replacement of the drying agent by the user	87
44.3	How to regenerate the drying agent.....	87
45	Maintenance and service life of the components	88
46	Optimum charging regime and storage conditions for maximum battery life	89
47	Cleaning.....	89
48	Warranty	90
49	Damages caused by misuse, maloperation, malfunction	90
50	Technical data L-Flame Pump Station	90
51	Technical data L-Flame Flame Head	92
52	Accessories.....	93
53	CE marking of the EU version	94
54	Address of the manufacturer and contact details for requesting an EU declaration of conformity	94

55 Use of the devices in the USA or Canada 94

1 Introduction

1.1 Safety instructions

Observe all safety instructions in this documentation! Safety instructions warn of dangers when handling devices and provide information on how to avoid them. They are classified according to the severity of the danger and divided into the following groups:

<p>DANGER</p> 	<p>Danger signals dangers for persons. If you do not follow the instructions for avoiding the hazard, the hazard will certainly result in death or serious physical injury.</p>
<p>WARNING</p> 	<p>Warning indicates dangers for persons. If you do not follow the instructions for avoiding the hazard, the hazard is likely to result in death or serious injury.</p>
<p>CAUTION</p> 	<p>Caution indicates danger to persons. If you do not follow the instructions for avoiding the hazard, the hazard is likely to result in minor physical injury.</p>
<p>NOTICE</p>	<p>Note signals dangers for objects or data. If you do not follow the instructions for avoiding the hazard, the hazard will probably result in damage to property.</p>
<p>TIP</p>	<p>A tip provides additional or supplementary information.</p>

1.2 Requirements the operator has to fulfill and necessary qualification

This product may only be operated by persons of legal age. In Germany the user must be at least 18 years of age.

This product may only be used within the scope of a professional and occupational activity.

The user must be a qualified person. A qualified person is a trained person who has experience with the technology of the device and is particularly informed about the types of energy used by the device and its size. Electrical and thermal types of energy (fuels) occur in this device.

The specialist is expected to use his training and experience to identify energy sources that can cause pain or injury and to take appropriate measures to protect against pain and injury from these energy sources. In addition, the practitioner must take appropriate measures to ensure that less trained persons cannot be injured. A qualified person can be trained either by the manufacturer of the device or by the customer who purchases the device.

Further qualifications such as stage pyrotechnician, SFX technician or professional fire worker is not required

Ensure that all legal requirements for the operation of flame projectors in the country of destination are met.

TIP

In Germany, these include the regulations of the employers' liability insurance association, e.g.:

- DGUV regulation 215-312: Safety at events and productions
- DGUV regulation 80: Use of liquid gas

1.3 General safety instructions when using the L-Flame and useful additional information regarding the technical status

This section is about general safety instructions. You need to mind other safety instructions given in this manual as well. Furthermore, you need to observe the safety distances mentioned in the relevant chapters.

The safety rules enlisted in this manual are referring to the L-Flame only. For the other devices in our product range there is another version of safety instruction which can be found in the user manual of the particular devices.

The following instructions are for your understanding about important and basic safety principles. Our general safety requirements are based on our own experience plus the contact and feedback from our customers. These rules allow the safe and successful usage of all components of our product range. With proceeding development of our products, we will continuously revise and adapt the safety standards in conclusion with your notifications and support.

The following safety instructions are part of all our operation manuals within our product range. These instructions are also available in printed form and can be downloaded via our internet homepage at any time. Please forward these instructions to any relevant persons in your company dealing with this topic.

Any technical device can potentially cause a fault. This could be encouraged through: wrong usage, unit damage, unit aging as well as the wear and tear of the unit. This fundamental thesis was the basic principle when writing these instructions.

The usage of effect devices to generate flame balls and flame columns, especially in indoor and outdoor venues or places of public assembly, can be hazardous and bears many potential risks, such as severe damage to property or personal injury and due to that is of utmost importance to follow all safety instructions whenever the product is being used.

1. Never use the devices if you have not completely read and understood the user manual.
2. Never order somebody to use devices in a potentially risky application if this person is not absolutely reliable or does not have sufficient technical knowledge.
3. The operator who is in charge for the safety has to have complete overview over all devices during the whole application. In addition, he has to be able to take action in the technical control of the system at any time if a potentially dangerous situation is arising. Please refer to the sections in this manual where the 'emergency off' functions are being explained.

4. For the usage of the device in places of public assembly an approval by the authorities that are responsible for the fire prevention is necessary.
5. If flame effects are being used no easily inflammable materials should be present in general. In places of public assembly this kind of material is normally forbidden by the legislator. By the usage of flame retardant spray these materials can be rendered hardly inflammable.
6. Smoking or open fire is strictly prohibited within the safety zone! Keep off any other sources of ignition.
7. Depending on the type, size and quantity of the effects that are being used and depending on the local conditions, allocate the necessary fire prevention and first aid measurements.
8. In all cases respect and follow any national and technical regulations as well as the operation manuals respective to the devices in use.
9. Ensure that the devices are standing securely and that the position or tilt cannot vary during the application. Depending on the circumstances it can be necessary to mount the devices e.g. by using screws. Please mind the chapter in this user manual which is dealing with the mounting of the devices on truss elements. Always use safety ropes if specified in the respective application.
10. Ensure that the devices are not covered by anything and that the fuel can be easily exhausted through the nozzle. Furthermore, ensure that no foreign objects like e.g. confetti or streamers enter the burning chamber.
11. Arm (switch on) the devices as shortly as possible before the effect and disarm (switch off) them immediately after the effect. Optionally this can be achieved either by using the emergency off input or the main switch or the hazard zones or the DMX safety channel. The hazard zones can be turned off and on either by a wireless command or by using serial data cables. As soon as the devices are armed or respectively ready to fire, they must be constantly supervised by the responsible operator.
12. Ensure that no heat sources like strong spotlights are pointed towards the devices or the fuel tanks.
13. Make sure that non authorized persons cannot gain access to the effect and control devices.
14. The safety boundary distances required by the manufacturer and authorities are to be respected. Secure the area so that non authorized persons cannot gain access to the same.
15. The operation manuals and safety instructions of the manufacturer of the effect and control devices must be observed at all times. If in doubt these must be discussed with the relevant safety organisations.

16. The effect and control devices are only allowed to be used according to the defined applications. Only use fuels that have been approved by the manufacturer.

17. The components of our firing system are to be covered or encased against burn-off cinders or weather conditions where necessary. Electrical contacts should be protected against corrosion, soiling and damage plus they should be cleaned regularly.

18. We recommend to have our products inspected every one to two years. Along with the testing of the rechargeable battery, a visual test as well as a functional test will prove that the operational safety standards are still met.

19. Do not use damaged equipment. If a damage is found, immediately send the device back to the manufacturer for professional repair. Our warranty for the proper function for our equipment is only for components of our system, which have no damage.

20. Any changes in or to the devices as well as repair work on the units other than that through the manufacturer will invalidate any warranty claims and our product liability will be void. Should repair of the units be necessary, then we do require a detailed report of the problem.

21. Please make sure when lending or renting out the equipment, that no damage has occurred during the rental period of the units. Advise your staff, that it is very important to report any possible damage of the units immediately. Customers, which have borrowed or rented the equipment are hereby informed, that it is their duty to report any damage found or suspected on the unit when returning such.

22. Empty the fuel tank completely before transport.

23. When transporting the devices make sure that the packing is sufficient and check the devices after each transport if they have been possibly damaged.

24. Wire connections between the devices of the L-Flame system and from control units are always to be insulated and must comply with the technical standards. At the same time avoid wire damage, for example through heat, cable twisting, cable pinching and burn-off cinders or through forced piercing. All cables must be checked for perfect condition before each use.

25. Avoid potential equalizing currents. Please note that these currents can occur between conductive parts of a building or between conductive parts of a building and earth potential. Due to that control lines should not have electrical contact to conductive structures or parts of a building. Potential equalizing currents on the shielding of cables or on control lines can cause malfunction.

26. Please be aware of the fact that through the flames ionized gases are created. The thereby produced ions increase the conductivity within the air. This ionization process can cause an electrical arcing especially within the vicinity of high voltage overland cables. This may lead to lethal consequences for the user

and other persons. Please note that wind conditions can be totally different a few meters above the ground.

27. Please assure that the effect can only be initiated through the operator. Keep the control unit under lock and key! Within our safety concept, all firing systems are set with individual codes, which inhibit unintended and accidental firing through third parties. If requested we can also supply systems with the same coding. This may be necessary if in a company more than one transmitter is used or when companies exchange the units between each other. It is possible to teach in the L-Flame Flame Head to any PFC Advanced to enable customers to easily exchange devices.

28. With our using the key code numbers 901 and 311, we are using a standard key code, which can also be found in other products. On a customer's request we can also supply other key codes.

29. Ensure that the safety distance is maintained by all persons. The safety distance is to be enforced from the beginning of the work and maintained until the release by the responsible operator at the end of the show until the closure of the fuel supply and the shutdown of the devices.

30. In the interest of your own safety, you should always use sufficiently long control cables and keep the greatest possible distance from the L-Flame Flame Heads.

31. During testing and firing of the devices no persons or animals are allowed in the hazard area. Furthermore, no materials that are heat-sensitive or that can catch fire are allowed in the same.

32. When the fuel is burning carbon dioxide is generated which is a suffocative gas if the concentration in the air is sufficiently high. Due to that ensure proper ventilation. If in doubt use CO2 warning devices.

33. To burn the fuel oxygen from the air is necessary. Do not use the device if the oxygen of the air is no longer present, e.g. if carbon dioxide or nitrogen is being used to generate low fog on stages. At least from the nozzle in the burning chamber of the L-Flame Flame Heads upwards a sufficient amount of oxygen must be present because otherwise the fuel cannot be ignited.

34. In applications that are critical in terms of safety you should consider safety measurements already during the setup how to safely dismantle the installation.

35. For any safety relevant questions please either contact the manufacturer or closely discuss these with the authorities in charge.

36. Rehearse the planned effect and the whole course of action several times together with all people that are involved, like artists, actors, participants, technicians and staff members of the security agency etc. and ensure that all possible hazards are ruled out. If this is not possible the effect must be cancelled. Inform

all participants about the function of the warning LED 'Attention, device armed' on the L-Flame Flame Heads.

37. Utmost care must be taken if material that can easily catch fire are present such as costumes, decoration material, fabrics or props etc.

38. If the smell of fuel, leakages, flow noise or leaked fuel (gasiform or liquid) is noticed it is not allowed to put the device into operation and the hazard area has to be cleared, left and barricaded immediately. Released fuel must be safely contained and disposed of.

39. Never bow over the L-Flame Flame Head or put parts of your body above or respectively before the fuel nozzle if the device is switched on and always keep at least the safety distance that is required so that no dangerous situation can arise.

40. Avoid forces to the quick couplers on the devices such as: drag forces, pushing and pulling forces and sidewise forces in all directions. If a hose is connected do not pull at the hose, no matter in which direction.

41. If a device did not function properly in an application it is not allowed to use it again until it has been repaired and checked by the manufacturer.

42. The hoses should only be connected when the system is depressurized, i.e. before the pressure control on the L-Flame Pump Station is switched on.

42. Before disconnecting the hoses, the system must be depressurized by switching off the pressure control at the L-Flame Pump Station.

43. The L-Flame system is not suitable for generating a continuous flame. On the one hand, flames that last too long cause a drop in pressure because the pressure accumulators are discharged. In addition, components can overheat if sufficiently long cooling times are not observed.

44. Only use original accessories. Otherwise, the safety of the equipment cannot be guaranteed. Further information can be found in the chapter 'Accessories' in the respective user manuals.

45. Either isopropanol (IPA), ethanol, bio-ethanol or Isopar L is allowed as fuel. The operator must be aware that isopropanol and the ethanols are significantly more dangerous and that accidents are significantly more likely to occur with these fuels. The user is responsible for accident-free operation. We recommend the use of Isopar L whenever possible. If unburned fuel falls to the ground, then isopropanol and ethanol can hit the ground or sensitive materials or even people. These fuels can easily catch fire. These fuels can even hit people while they are already burning and falling. Extreme care must be taken not to release isopropanol or ethanol in the event of a leak. Even small amounts of isopropanol or ethanol can cause burning stages because these fuels have several problematic properties:

- They evaporate heavily, even at low temperatures.
- They are highly flammable.
- They act as fire accelerants.

For these reasons, we do not recommend using isopropanol or ethanol on stages, not indoors and not outdoors. The only application that allows the use of isopropanol or ethanol is when the entire L-Flame system is set up in a clear and plain area with large safety distances to the stage and the spectators. The necessary safety distances must be determined by the user. Once the system is pressurized the Flame Heads must be treated as armed. No one is allowed to be in the danger zone during this time. Do not touch or come close to the electrodes. The high voltage source is very powerful and can be lethal.

46. When you power-on the Pump Station, the device is not automatically measuring the fuel level in the tank. This is performed when you activate the magnetic sensor next to the led bar graph. The reason for this is that in order to measure the level a valve needs to be opened to equalize the pressure in the tank with the air pressure. Especially if IPA or ethanol is used, significant vapour pressure can build up in the tank. When the valve is opened, gasiform fuel may be set free which bears a risk. Due to that, we do not want the valve to open automatically without any user action.

47. The devices have a number of monitoring functions (leakage monitoring, flame monitoring, ignition coil monitoring, tilt switch, XY tilt sensing). In case of any problems with one of these monitoring functions, you can turn them off individually. As long as no permanent problem occurs all these functions should be enabled.

48. The pan/tilt sensors are measuring the G-force of the earth. By performing certain calculations (tan, arctan) the pan/tilt angles can be determined out of three acceleration values (X, Y and Z axis). This means that movement and vibration of the Flame Head can cause significant measurement errors. It is likely that you need to turn off the pan/tilt sensing if the Flame Heads are exposed to movements, mechanical shocks or vibration during the application. E.g. bass speakers in close proximity can cause problems of this kind.

49. The L-Flame heads use an optical flame sensor for flame monitoring. A special IR filtering is used here, so only a real flame will be detected (no sunlight, no light sources on stages, no UV, no IR from hot surfaces). The transparent disc of the flame monitoring system should be clean. Thick rain or fuel drops on the disc may cause signal attenuation so it is recommended to keep this surface always clean and dry. Experience must be gained if impregnation spray can be used to make rain drops less critical. It might be necessary to disable the flame monitoring if the heads are used in heavy rainfall. The angle of this optical sensor is rather wide. Heads should not be operated too close together, so that the flame of one head cannot generate a signal in the flame monitoring system of the neighbouring heads. It is planned to install a small tube above the sensor chip to limit the detection angle but here we need to do some more testing. Taping a disc with a hole, e.g. a bigger washer, onto the sensor window could also be a method of angle limitation until we have gained more experience how to design the internal tube.

50. When three heads are firing simultaneously, the flames become significantly lower after approx. 2.5 seconds. Pumps are then running permanently and the pressure in the Pump Station is around 9 bar. Heads start to spit at this low pressure. We could offer an intermediate pressure accumulator to be inserted in the fuel hose between Pump Station and Flame Head if longer flames are desired. With long flame durations, the fuel consumption is of course much higher. We used IPA for testing because it does not make a mess if there is a leakage.

51. When pressurising the system you should wait until pressure is stable before firing any flame cues. It takes a while until all pressure accumulators are completely charged.

52. Continuous charging of the Pump Station is recommended when possible. The current drawn from the battery when firing is in the range of 120 A. That is a lot and in the range of an engine starter of a car which is running only some seconds.

53. The volume display (Litres or US liquid gallons) and the tank level display in the Pump Station disregard the minimum amount of fuel that needs to be in the tank so that no air is sucked in. This is approx. 3 Litres. When you drain the tank by opening the drain screw, you need to know that. If the unit displays that 17 Litres are in the tank approx. 20 Litres will come out.

54. When the contact of the Emergency Off input is open, no power is supplied to the Flame Heads anymore. The Pump Station goes into Fail Safe if it detects an open contact in normal mode. With newer firmware the Pump Station is checking the Emergency Off input in most operating situations.

55. Before displaying "Fail Safe" the Pump Station is depressurising the system and the heads if there is no tank overflow. In Fail Safe a text regarding the occurred malfunction is being displayed.

56. Flame Heads may spit at the beginning after setting up if air is the system or hoses.

57. The Pump Station has two tank overflow sensors at different levels. In an overflow condition the unit does not allow depressurizing in order to prevent that fuel flows into the drip tray via the overpressure valve. During normal operation, there is an anti-sloshing function in the firmware so that a short fluid detection at the sensors do not cause a reaction.

58. When you fill in fuel into the tank of the Pump Station you should always activate and watch the fuel level indicator to be able to avoid overflow. Fill in the fuel slowly.

59. When the Pump Station detects an almost empty tank the fuel supply to the Flame Heads is stopped, all Flame Heads stop flames, the fault LED on the Pump Station is on and an information screen is being displayed. Now you can refill the tank. At a level of $\geq 4\%$ the Pump Station continues to pump fuel and Flame Heads will continue as well. In this case, you should pause flame cues until pressure is established again.

60. The Pump Station and the Flame Heads have Leakage Monitoring. The Pump Station is monitoring its internal system up to the fuel output connectors. The Flame Heads monitor their hoses and the components inside the heads. When generating a flame the heads request fuel. In this moment, the Leakage Monitoring in the heads is turned off. The fuel request is stopped ten seconds after the fuel valves in the head are closed. Then the pressure should settle and after another four seconds the pressure is measured and the Leakage Monitoring is started. The Pump Station waits seven seconds after the last time the pumps were on and then measures the internal pressure and starts Leakage Monitoring. It is important to understand that the Leakage Monitoring is not always in operation: When pressurising, when generating a flame, when pumping and shortly after flames have been generated and during and after re-establishing pressure. It is necessary to watch over the system very closely in these monitoring gaps. The Leakage Monitoring function compares the actual pressure with the stored pressure reading when the function became active. An unintended or unexplainable pressure loss is interpreted as a leakage. The loss of pressure due to falling ambient temperature (from +25°C down to -20°C) or rolling out of hoses has been taken into account when calculating the threshold for the maximum allowable pressure loss. We will also try to analyse the minimum pressure that occurs while all three fuel valves are open and all pumps are running to detect heavy leakages even in the monitoring gaps but we do not have this data yet. With the planned protocol the heads will inform the Pump Station about a detected leakage so that the Pump Station can depressurize everything and enters Fail Safe afterwards. Now the Pump Station goes into Fail Safe only if an internal leakage has been detected.

61. In case of a Fail Safe condition a hard reset is required. You need to switch off the Pump Station, wait some seconds and the power-up the unit again.

62. If the Pump Station is switched on the device measures the system pressure and runs a depressurising cycle if more than 0,3 bar are detected.

63. Depressurise the system before you dismantle the setup. Use the menu function for this purpose.

64. With any pump action or fuel level measurement, the tank ventilation valve will be opened. Gasiform IPA might be set free during that due to the high vapour pressure of IPA. The warmer the IPA the more serious this problem becomes. Take all necessary safety measures to prevent dangerous situations arising from that. With Isopar L this problem is less critical.

65. DMX is not decoded by the Pump Station but only by the Flame Heads. The Pump Station is only used to distribute DMX to the Flame Heads. In order to maintain a line shaped network architecture, the signal from the DMX input is routed first to Flame Head 1, then back to the Pump Station, then to Flame Head 2, again back to the Pump Station, then to Flame Head 3 and then back to the Pump station to be present on the output again for daisy chaining the DMX signal to the next device. If only two or only one Flame Head is connected the

Pump Station bridging the data ports of the unused heads is necessary. In order to route the signal correctly you have to select the appropriate DMX routing in the menu of the Pump Station. Only the following setups are possible: Head 1 + Head 2 + Head3 or Head 1 and Head 2 or solely Head 1. It is planned to implement a Flame Head detection function so that the device selects the correct signal routing automatically.

1.4 Application fields and intended use

The L-Flame system is a very universal flame system, which can be used outdoors, on stages, in buildings, indoors and in tents, provided that all safety instructions and safety distances are observed.

Typical applications are:

- Flame shows outdoors, solely or combined with aerial fireworks displays or ground fireworks
- Generation of flame effects in very large venues
- Applications on stages in buildings e.g. for TV productions or on open-air stages e.g. during a live-concerts
- Generation of flame effects in the area of special effects for TV and movie productions
- Hazard training for fire fighters, policemen, special and military forces

All other applications are considered as unintended and must be approved by the manufacturer.

The units are not designed to produce continuous flames. No more than 2.5 seconds should be programmed as the maximum burning time. Later, special nozzles may be offered, for which reason up to 25 seconds can be programmed in the menu. It should be avoided that only because of new nozzle variants a firmware update is necessary. Therefore, the extremely wide setting range for flame duration and pressure.

Besides long-lasting continuous flame columns are much less dramatic compared to short flame balls and flame columns.



1.5 Required approvals

Before the device can be used, a permit by the owner and if applicable of the tenant of the property or building is required.

For the usage outdoors - if it is not a stage or a place of public assembly - no permit of any authority is required to the best of the manufacturer's knowledge. Usually no charges can be imposed for this kind of usage.

In places of public assembly and on stages the relevant local laws must be followed. The necessary fire precautions must be negotiated with the competent authority for fire prevention depending on the individual case.

2 General warnings and notes regarding the Pump Station

<p>WARNING</p>   <p>1.1 1.2</p>	<p>Danger due to weight of the unit and flammable liquids</p> <p>Wear the following personal protective equipment (PPE) when using the equipment:</p> <ul style="list-style-type: none"> • Safety shoes • Safety goggles
--	---

<p>WARNING</p>  <p>1.5</p>	<p>Leakage</p> <p>Fuel-carrying lines can leak.</p> <ul style="list-style-type: none"> • Check connections for leaks. • Follow all instructions in the operating manual regarding maintenance. • Do not use the device if leaks are detected. • Follow all safety instructions and regulations at all times.
--	---

<p>WARNING</p>  <p>2.3.1</p>	<p>Overfilling the tank</p> <p>Overfilling and spreading of flammable liquids on the unit can occur during refuelling.</p> <ul style="list-style-type: none"> • Use the integrated fill level measurement with visual and acoustic feedback on the fill level. • Follow all safety instructions and regulations at all times.
--	--

<p>WARNING</p>  <p>2.1.2 2.5.1</p>	<p>Weight</p> <p>The unit is very heavy.</p> <ul style="list-style-type: none"> • Use suitable means of transport. • Do not carry the unit alone. • Ensure that the ground is sufficiently stable. • Use personal protective equipment (PPE). • Follow all safety instructions and regulations at all times.
--	--

<p>WARNING</p>  <p>2.3.6</p>	<p>Unintentional triggering of flame effects when splitting Galaxis systems into two or more systems by the customer</p> <p>The simultaneous operation of systems that vary only in terms of different radio channels constitutes a safety risk.</p> <p>When two or more Galaxis systems are in use:</p> <ul style="list-style-type: none"> • Make sure that you have assigned different System IDs to the systems.
---	---



<p>NOTICE</p> <p>2.1.1</p>	<p>Overturning the device</p> <p>The device may overturn during operation.</p> <ul style="list-style-type: none"> • Ensure a sufficiently secure stand. • Only set up the unit on a level surface.
-----------------------------------	---

<p>NOTICE</p> <p>2.6.1</p>	<p>Charging the device</p> <p>The device may only be charged in certain positions.</p> <ul style="list-style-type: none"> • Charge the device only in normal position.
-----------------------------------	--

<p>WARNING</p> 	<p>Explosion hazard, fire hazard</p> <p>Explosion of vapors, ignition of fuel.</p> <ul style="list-style-type: none"> • During operation, the tank is partially ventilated. • Therefore, keep ignition sources away from the 'Tank Vent' opening. • Fuel may be released during certain menu items. Keep ignition sources away from a large area. • Observe all safety rules and regulations at all times.
---	---

Please also take note of the other warnings given elsewhere in this user manual.

3 General warnings and notes regarding the Flame Head

<p>WARNING</p>   <p>1.1 1.2</p>	<p>Danger due to weight of the unit and flammable liquids</p> <p>Wear the following personal protective equipment (PPE) when using the equipment:</p> <ul style="list-style-type: none"> • Safety shoes • Safety goggles
---	---

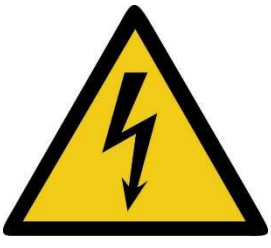
<p>WARNING</p>  <p>2.3.3</p>	<p>High voltage at the ignition electrodes</p> <p>For the operation of the electrical ignition of the fuel a very high voltage is generated in the device, which can be life-threatening.</p> <p>Never touch the ignition electrodes during operation.</p>
--	---

<p>CAUTION</p> 	<p>Strong heating of the device during operation</p> <p>During operation, the following parts of the device can heat up considerably:</p> <ul style="list-style-type: none"> • the casing, in particular the parts forming the combustion chamber • the ignition electrodes
---	--

<p>2.4.3 2.5.1</p>	<p>Do not touch these parts until they have cooled down sufficiently and the unit is switched off.</p>
------------------------	--

<p>WARNING</p>  <p>1.5 2.3.5</p>	<p>Leakage</p> <p>Fuel-carrying lines can leak.</p> <ul style="list-style-type: none"> • Check connections for leaks. • Follow all instructions in the operating manual regarding maintenance. • Do not use the device if leaks are detected. • Follow all safety instructions and regulations at all times.
--	---

<p>WARNING</p>  <p>2.2.2 2.3.4 2.4.2</p>	<p>Unintentional triggering of a flame column</p> <p>Technical faults can lead to unintentional flame effects.</p> <ul style="list-style-type: none"> • Make sure that the required safety distance to persons is maintained. • Only connect the fuel-carrying lines when they the device is switched off. • Minimize the presence in the danger zone. • Enable the flame monitoring system. • Never keep body parts above the combustion chamber at any time. • Follow all safety instructions and regulations at all times.
---	--

<p>DANGER</p>  <p>2.3.1</p>	<p>Open flames</p> <p>Personal injury can occur due to the open flame.</p> <ul style="list-style-type: none"> • Make sure that the required safety distance to persons is maintained. • Minimize the presence in the danger zone. • Never keep body parts above the combustion chamber at any time. • Follow all safety instructions and regulations at all times.
---	---

<p>WARNING</p>  <p>2.3.2</p>	<p>Ignition failure</p> <p>The ejected fuel does not ignite.</p> <ul style="list-style-type: none"> • Make sure that the required safety distance to persons is maintained. • Minimize the presence in the danger zone. • Activate the flame monitoring system. • Never keep body parts above the combustion chamber at any time. • Follow all safety instructions and regulations at all times.
--	--

<p>WARNING</p>  <p>2.3.6</p>	<p>Unintentional triggering of flame effects when splitting Galaxis systems into two or more systems by the customer</p> <p>The simultaneous operation of systems that vary only in terms of different radio channels constitutes a safety risk.</p> <p>When two or more Galaxis systems are in use:</p> <ul style="list-style-type: none"> • Make sure that you have assigned different System IDs to the systems.
--	---

<p>NOTICE</p> <p>2.1.1</p>	<p>Overturning the device</p> <p>The device may overturn during operation.</p> <ul style="list-style-type: none"> • Ensure a sufficiently secure stand. • If necessary, attach the unit to the designated mounting points. • Always enable the tilt switch if possible.
-----------------------------------	---

Please also take note of the other warnings given elsewhere in this user manual.

4 Illustration and description of indicators and control elements

4.1 Pump Station



1, 2	Carrying handles	The handles are on both sides and they are intended to lift and carry the device by two persons.
3	Tank inlet	Here, the sealing cap is to be screwed on, which is only removed during filling.
4	LED bargraph filling level	A sensor field for the magnetic pen is used to activate the measurement.
5	Bubble level	Serves to align the device on level stand. The air bubble must be in the inner ring. Only then is the operation safe.
6	Lemo socket Refuel Station	The data cable of the Refuel Station is connected here.
7	Hydraulic connection Refuel Station	The fuel hose of the Refuel Station is connected here.
8	LC Display	Displays the current information.
9	LED 'Operation'	This blue LED is continuously on if the device is in the menu and it is flashing if the device is in stand-by mode or ready to fire.
10	LED 'Charging'	This green LED is lit if the device is being charged.
11	LED 'Low Battery'	If the battery is discharged below 30% this red LED is flashing in stand-by mode or if the device is ready to fire.
12	LED 'Fault'	Lights up red when there is a fault.
13	Magnetic sensitive area 'Up'	For changing the parameter currently shown in the display. In standby mode, it can be used to select various displays. In the menu, this control element is used to increase a parameter or select a function (Yes).
14	Magnetic sensitive area 'Down'	For changing the parameter currently shown in the display. In standby mode, it can be used to select various displays. In the menu, this control element is used to decrease a parameter or not to select a function (No).
15	Magnetic sensitive area 'Mode'	To call the menu and to go to the next menu item. Also 'Do not change and continue' and thus partly identical with 'Down'.
16	DMX input and output, XLR 5-pin	Use either this or the other input or output. The inputs are connected internally, as are the outputs.
17	DMX input and output, XLR 3-pin	Use either this or the other input or output. The inputs are connected internally, as are the outputs.
18	Main switch	Switching off should normally only take place in standby mode.
19	Connector for emergency off switch	Connect the Emergency Stop switch here. No operation is possible without the Emergency Stop switch in the 'On' position.
20	Hydraulic connection Empty Tank	A hose can be connected here if fuel is to be pumped back into a container.
21	Connector for Charging Unit, XLR 3-pin	For connecting the supplied charger.
22	Connector Tank Vent	A hose can be connected here to vent the produced fuel vapors to a safe area.
23	Lemo socket Flame Head Power Supply	three adjacent present for Flame Head 1 to 3
24	Lemo socket Flame Head Data Cable	three adjacent present for Flame Head 1 to 3
25	Hydraulic connection Flame Head Fuel Supply	three adjacent present for Flame Head 1 to 3
26	Housing foot	six times in total present on the underside of the housing

4.2 Flame Head



1	Housing foot	six times in total present on the underside of the housing
2	Guiding slot for slot nut	A total of six times in pairs to insert sliding nuts.
3	Socket 'Antenna'	BNC connector for the supplied standard antenna
4	Carrying handle	Use this handle to carry the device.
5	Antenna	standard antenna, included in delivery
6	Nozzle	The nozzle is screwed into a thread here and can be changed if necessary.
7	Wind shield	This piece of pipe improves the ignition behavior in windy conditions.
8	LED 'Operation'	This blue LED is continuously on if the device is in the menu and it is flashing if the device is in normal mode.
9	LED 'Flame'	This yellow LED lights continuously when a flame is generated and flashes while a step delay is in progress.
10	LED 'Low Battery'	If the battery is discharged below 30% this red LED is flashing in normal mode.
11	LED 'Fault'	Lights up red when there is a fault.
12	Magnetic sensitive area 'Up'	For changing the parameter currently shown in the display. In normal mode, it can be used to select various displays. In the menu, this control element is used to increase a parameter or select a function (Yes).
13	Magnetic sensitive area 'Mode'	To call the menu and to go to the next menu item. Also 'Do not change and continue' and thus partly identical with 'Down'.
14	Magnetic sensitive area 'Down'	For changing the parameter currently shown in the display. In normal mode, it can be used to select various displays. In the menu, this control element is used to decrease a parameter or not to select a function (No).
15	LC Display	Displays the current information.
16	Warning LED 'Attention device is armed'	Flashes in red color if the device is armed or while the safety timer is counting down. Can be disabled in the menu.
17	Carrying handle	Use this handle to carry the device.
18	Wind shield	This piece of pipe improves the ignition behavior in windy conditions.
19, 20	Ignition electrodes	present in double version
21	Window for flame sensor	This sensor works optically. The glass surface should always be clean.
22	Display housing	for the LC display, LEDs and control elements
23	Antenna	standard antenna, included in delivery
24	Socket 'Antenna'	BNC connector for the supplied standard antenna

The type plate of the device is located on the underside.

4.3 Carrying handles at the Pump Station

There are two carrying handles on each side of the Pump Station.

To carry the device, swing out these handles. It is recommended to carry the device with two persons only.

Flip the handles back in when you no longer need them.

5 Safety distances

Conditions: vertical stand, no wind

to the side: 4.0 m

upwards: 4.0 m from the last flame ends

Examples:

For a flame height of 10.0 m, the safety distance upwards is 14.0 m.

For a flame height of 15.0 m, the safety distance to the top is 19.0 m.

In case of wind from the side or if the flame is installed at an angle, the lateral safety distance must be increased. The lateral distance to the flame must always be at least 4.0 m.

In addition, no unburned fuel may fall on persons or combustible material (fallout).

The stronger the wind from the side, the more fallout can occur and the further the fallout can be carried. It is at the judgment of the user how far to increase the safety distance. It is the user's responsibility to ensure that no accidents occur or damage is done.

It is also strongly recommended to use Isopar L instead of isopropanol (IPA) or ethanol, as it is far less hazardous.

<p>WARNING</p>  <p>2.2.2 2.3.4 2.4.2</p>	<p>Unintentional triggering of a flame column</p> <p>Technical faults can lead to unintentional flame effects.</p> <ul style="list-style-type: none"> • Make sure that the required safety distance to persons is maintained. • Only connect the fuel-carrying lines when the device is switched off. • Minimize the presence in the danger zone. • Enable the flame monitoring system. • Never keep body parts above the combustion chamber at any time. • Follow all safety instructions and regulations at all times.
---	---

<p>DANGER</p>  <p>2.3.1</p>	<p>Open flames</p> <p>Personal injury can occur due to the open flame.</p> <ul style="list-style-type: none"> • Make sure that the required safety distance to persons is maintained. • Minimize the presence in the danger zone. • Never keep body parts above the combustion chamber at any time. • Follow all safety instructions and regulations at all times.
---	---

<p>WARNING</p>  <p>2.3.2</p>	<p>Ignition failure</p> <p>The ejected fuel does not ignite.</p> <ul style="list-style-type: none"> • Make sure that the required safety distance to persons is maintained. • Minimize the presence in the danger zone. • Activate the flame monitoring system. • Never keep body parts above the combustion chamber at any time. • Follow all safety instructions and regulations at all times.
--	--

6 The LED indicators at the Pump Station

This section describes the LED indicators which can be found right above the display:

6.1 The LED 'Operation' (blue)

This blue LED displays the operating mode. While the device is in the menu this LED is continuously on. In this case no flame effect can be initiated.

If the device is in normal mode this LED is flashing. Only if this is the case a flame effect can be generated.

6.2 The LED 'Charging' (green)

This green LED is on as soon as the charging voltage is present and the battery is being charged.

When the battery is fully charged, this LED will turn off automatically.

6.3 The LED 'Low Battery' (red)

This LED starts to flash in red color in the normal mode if the internal battery has been discharged below 30% and together with the flashes you will hear an acoustic warning signal if the loudspeaker has been enabled. In such a case you should connect the charger soon in order to charge the battery completely again. A full charge takes up to 20 h.

6.4 The LED 'Fault' (red)

This LED lights up red as soon as a fault is present. In such a case, you will see further information in the display or in the menu of the device or via remote data request.

7 The LED indicators at the Flame Head

This section describes the LED indicators which can be found right above the display:

7.1 The LED 'Operation' (blue)

This blue LED displays the operating mode. While the safety timer is counting down or the device is in the menu this LED is continuously on. In this case no flame effect can be initiated.

If the device is in receiving mode or ready to fire mode this LED is flashing. Only if this is the case a flame effect can be generated.

7.2 The LED 'Flame' (yellow)

This LED lights up yellow as soon as and as long as the magnetic valves are open.

If the Advanced radio module is installed, you can program so-called step delays, i.e. delay times, in the menu of the device or remotely via radio.

If a step delay has been programmed and the ignition command for it is received by the unit, this LED flashes until the magnetic valves open. During the flame effect, this LED then lights up continuously.

7.3 The LED 'Low Battery'

This LED starts to flash in red color in the receiving mode or respectively ready to fire mode if the internal battery has been discharged below 30% and together with the flashes you will hear an acoustic warning signal if the loudspeaker has been enabled. In such a case you should connect the charger soon in order to charge the battery completely again. A full charge takes up to 20 h.

7.4 The LED 'Fault' (red)

This LED lights up red as soon as a fault is present. In such a case, you will see further information in the display or in the menu of the device or via remote data request.

8 Inputs, pin assignments and usage of electrical connectors

8.1 The emergency off input (E-Stop)

A shielded cable with two stranded wires that are wired to an electrical switch can be connected here. The emergency off switch (E-Stop) should be installed in an enclosure. Industrial grade emergency off switches, suitable housings, cables and accessories are available on the market for do-it-yourself constructions. Upon request we can also supply this material or offer a ready-for-use solution.

Several L-Flame Pump Stations should always be controlled by separated emergency off switches to avoid potential equalizing currents. If you want to control several L-Flame Pump Stations with a single emergency off switch we can offer you a solution with an optical isolator between the individual signals.

As standard, we offer 8-way and 16-way emergency off (E-Stop) distributors as accessories for this purpose.

The pin assignment of the emergency off input is as follows:

Pin1 = Shielding for the control signal, to be connected with the shielding of the cable
Pin2 = to be connected with the contact of the electrical switch (output at the L-Flame Pump Station)
Pin3 = to be connected with the contact of the electrical switch (input at the L-Flame Pump Station)

8.2 The DMX512 input and output

The DMX512 signal is fed into the Pump Station and forwarded to the Flame Heads one after the other.

For this routing to work correctly, please note the menu item "DMX512 and RS485 Routing" in the submenu of the Pump Station.

DMX512 is the widely used protocol for controlling lighting equipment. It is transmitted on a RS485 interface. The RS485 standard defines how this interface works in terms of hardware and which network topology must be used.

The DMX signal fed to the Pump Station is routed to the first Flame Head and back to the Pump Station. Then to Flame Head 2 and back. Then to the third Head and back. Then it is available again at the DMX output of the Pump Station and can be routed to the next DMX device.

This signal routing is necessary because a linear network topology is mandatory for the RS485 interface.

It is also important to know that only the Flame Heads and not the Pump Stations decode DMX. Therefore, it is not possible to set DMX channels for the Pump Station.

It should also be mentioned that instead of DMX512, wired communication between a PFC Advanced and the Flame Heads is also possible via this interface. Therefore we speak of "DMX512 and RS485 Routing" and not only of "DMX512 Routing".

For both input and output, 3-pin and 5-pin XLR panel jacks and XLR panel plugs are available. Therefore, you are always free to choose which cable you want to use.

A connector with a termination resistor of 110 Ohm must be installed at the last device in the DMX line.

Up to 32 DMX devices can be operated in a single DMX line. If this is not sufficient you need to use a DMX splitter.

Please note that for DMX signals only shielded twisted-pair cables with lowest possible capacitance and an impedance of 110 Ohm are allowed to be used. Only used cables that are specified according to the DMX standard. E.g. normal microphone cables are in no case suitable for this purpose.

The pin assignment is as follows:

Pin1 = Shield, to be connected with the shielding of the cable, also ground for wireless DMX pens
 Pin2 = Signal -
 Pin3 = Signal +

If present:

Pin4 = unassigned but connected with the same pin on the other jack (to enable the feedthrough of return signals) or +5VDC power supply for wireless DMX pens

Pin5 = unassigned but connected with the same pin on the other jack (to enable the feedthrough of return signals)

If you want to supply wireless DMX receivers with power, then you can switch this power supply on or off in the submenu of the Pump Station. The menu item is called "Power supply for Wi-DMX". This makes it possible to operate the L-Flame autonomously, i.e. completely independent of any voltage sources, even in DMX mode.

Attention: The DMX protocol is considered to be unsafe because no checksum is being transmitted. Usually it is not allowed to control pyrotechnic effects or similar with DMX. The user solely bears the risk of any potential damages caused by a malfunction. To improve safety, we have implemented the arming of the device by using a safety channel in the L-Flame Flame Heads.

TIP	For the reason of safety, the L-Flame Flame Heads should always be operated in an exclusive DMX universe, that is only used for the flame effects and no other devices. On all unused DMX channels, the dimming value 0% (decimal 0) should be transmitted.
------------	---

8.3 Control via DMX512

In order for a flame to be generated, the safety channel must be transmitted with a dimmer value that is within the previously configured range. See entries in the table under 'The 'Safety channel' menu item'.

First the safety condition must be met before the flame channel can initiate the generation of a flame!

The safety condition is only correctly fulfilled if the dimmer value of the flame channel is below 6% (below decimal 15) during the rising edge of the dimmer value of the safety channel.

A flame will be generated if the safety condition is met and the flame channel is being received with a dimmer value of at least 90% (at least decimal 229).

Another flame effect can only be triggered if the dimmer value of the flame channel dropped below 6% (below decimal 16) in the meantime.

If a flame is being generated currently and the safety channel is being received with a dimmer value outside the previously configured value range, the electromagnetic fuel valves are closed to stop the flame effect.

It can be meaningful to program the L-Flame Flame Heads with different flame channels and a common safety channel. If you move the fader of the safety channel beyond the valid range all L-Flame Flame Heads will be deactivated together. It is still possible to program groups of safety channels if necessary.

Examples of the display content while receiving DMX signals:

Input: DMX512
F:003_, S:012X

The L-Flame Flame Head has been programmed to flame channel 3 and safety channel 12 ('F' = Flame channel, 'S' = Safety channel). In addition, you see the status of the safety channels and respectively of the DMX reception. 'x' means that no signal is being received or that the transmitted value of the safety channel is not within the previously configured value range (= device is not armed). The safety condition is not met in this example and no flame is being generated.

Input: DMX512
F:003_, S:012✓

'✓' right next to the safety channel means that a DMX signal is being received and a value between the previously configured value range is being received for the safety channel (= device is armed). Consequently, flame effects can be initiated.

Input: DMX512
F:003δ, S:012✓

The safety condition is fulfilled and the flame channel is being received with a dimming value of at least 90%. The L-Flame Flame Head generates a flame. In this case a flame symbol is being displayed right next to the flame channel.

During the reception of DMX signals in addition to the display content shown above also the following information is being displayed alternately:

- Flame monitoring on/off
- Leakage monitoring Flame Head and hose on/off
- Ignition coil monitoring on/off
- Tilt switch on/off and the tilt status
- Pan/tilt sensor status on/off, OK or exceeded
- Pressure and pressure control on/off

As soon as the DMX status is changing the device immediately displays the DMX information again and the LCD backlight is switched on simultaneously if it has been enabled in the menu of the device.

8.4 Charging of the Pump Station

The battery for the power supply of the Pump Station and the heads is installed in the housing of the Pump Station.

To charge the Pump Station connect it to the supplied charging unit and establish mains supply. The charging unit comes with a universal voltage input and can therefore be operated worldwide. All you might need are adapters for the different national standards of wall outlets.

If the accumulator needs a full charge 20h are required. The intelligent charging circuit switches to trickle charge afterwards. Damages from overcharging cannot occur.

The LED 'Charging' is active in green color while the battery is being charged.

When the battery is fully charged, this LED will turn off automatically.

NOTICE 2.6.1	<p>Charging the device</p> <p>The device may only be charged in certain positions.</p> <ul style="list-style-type: none"> • Charge the device only in normal position.
----------------------------	--

TIP	Continuous operation is possible in normal mode by constantly charging the device.
------------	--

TIP	After incomplete charging, a slightly higher battery capacity is displayed because the battery voltage has not yet normalized. Wait for an operating time of approx. 10 minutes to measure realistic values.
------------	--

9 Approved fuels and their advantages and disadvantages

<p>WARNING</p>  <p>2.2.2 2.3.4 2.4.2</p>	<p>Unintentional triggering of a flame column</p> <p>Technical faults can lead to unintentional flame effects.</p> <ul style="list-style-type: none"> • Make sure that the required safety distance to persons is maintained. • Only connect the fuel-carrying lines when they the device is switched off. • Minimize the presence in the danger zone. • Enable the flame monitoring system. • Never keep body parts above the combustion chamber at any time. • Follow all safety instructions and regulations at all times.
--	--

<p>DANGER</p>  <p>2.3.1</p>	<p>Open flames</p> <p>Personal injury can occur due to the open flame.</p> <ul style="list-style-type: none"> • Make sure that the required safety distance to persons is maintained. • Minimize the presence in the danger zone. • Never keep body parts above the combustion chamber at any time. • Follow all safety instructions and regulations at all times.
---	---

The following fuels are permitted for the Pump Station and associated Flame Head operation:

9.1 Isopropanol, also known as IPA

Advantages:

- can be atomized well
- ignites easily, even at low temperatures
- burns with a low-smoke bright yellow flame
- the flame produces relatively little heat radiation

Disadvantages:

- burning fallout can reach the ground
- fallout continues to burn e.g. on the floor
- must be labeled and transported as hazardous goods
- air freight is expensive and complicated

Attention! The user must be aware that the use of IPA is much riskier than Isopar L and bears sole responsibility if damage occurs as a consequence.

9.2 Isopar L

Advantages:

- easier transport
- less regulations for air freight transport
- bright yellow flame
- the smoke produced is sometimes desirable, the flame looks more martial

Disadvantages:

- is not so easy to atomize
- not so ignitable, especially in cold temperatures
- produces a lot of smoke during combustion which is why indoor use is not always possible
- high heat radiation due to high calorific value

9.3 Ethanol and bio-ethanol (also organic ethanol)

Advantages:

- can be atomized well
- ignites easily, even at low temperatures
- burns with a low-smoke flame
- the flame produces relatively little heat radiation

Disadvantages:

- the flame does not burn as intensively and is too dark for some applications
- burning fallout can reach the ground
- fallout continues to burn e.g. on the floor
- must be labeled and transported as hazardous goods
- air freight is expensive and complicated



Attention! The user must be aware that the use of ethanol or bio-ethanol is much more risky than Isopar L and bears sole responsibility if damage occurs as a consequence.

10 Additives forbidden for colored flames and other fuels

No substances may be added to the fuels. In particular, do not add substances that produce colored flames. These substances are often very aggressive and can damage the internal systems of the devices. The warranty expires immediately if not pure or other than the permissible fuels are used.

11 Personal protective equipment

All components of the L-Flame system are very heavy. Combustibles could spray into the face. Therefore, wear personal protective equipment such as safety shoes and safety goggles. Observe the applicable regulations of the employers' liability insurance associations. In certain situations, gloves and a helmet may also be required.

<p style="text-align: center;">WARNING</p> <div style="text-align: center;">   </div> <p style="text-align: center;">1.1 1.2</p>	<p>Danger due to weight of the unit and flammable liquids</p> <p>Wear the following personal protective equipment (PPE) when using the equipment:</p> <ul style="list-style-type: none"> • Safety shoes • Safety goggles
---	---

12 Installation of the L-Flame system

Always position the Pump Station horizontally and install the Flame Heads. Only when the Pump Station is positioned horizontally will the tank sensor for detecting internal leaks in the Pump Station be able to function correctly.

Then make all hose and cable connections. Make sure that all cables and hoses are plugged in correctly. Cables and hoses from Flame Head 1 must be plugged into the connections for Flame Head 1. The same applies to Flame Head 2 and 3.

Turn on the Pump Station, and thereby also the Flame Heads, by turning the main switch on the Pump Station to the 'on' position.

Fill the tank while observing the filling level by means of the filling level measuring function.

<p>WARNING</p>  <p>2.3.1</p>	<p>Overfilling the tank</p> <p>Overfilling and spreading of flammable liquids on the unit can occur during refuelling.</p> <ul style="list-style-type: none"> • Use the integrated fill level measurement with visual and acoustic feedback on the fill level. • Follow all safety instructions and regulations at all times.
--	--

Pressurize the system if flame effects are to be generated. From this point on, you must also always have the system monitored by a trained person in order to be able to intervene immediately in the event of leaks or other malfunctions. Depressurize the system immediately by turning off the pressure control if a problem occurs.

Create the desired flame effects.

Refill the tank as needed.

If no more effects are to take place, then depressurize the system by turning off the pressure control.

For safety reasons, do not pressurize the system unnecessarily for extended periods of time if no flame effects are imminent.

13 Dismantling the L-Flame system

If no more effects are to be performed, then first depressurize the system by switching off the pressure control.

If you wish, you can pump out the tank by calling up the menu item provided for this purpose. An alternative to pumping out is to open the drain screw of the tank which is located on the underside of the Pump Station.

Switch off the system by turning the main switch on the pump station to the "off" position.

You can now disconnect all cable and hose connections and dismantle the equipment.

14 Tilting of the L-Flame Flame Head

In general, the L-Flame Flame Head can also be operated at an angle.

However, it should be noted that the tilt sensor does not work correctly at an angle of approx. $\pm 90^\circ$ for technical reasons. Therefore, it should be switched off when the tilt setpoint plus set angle tolerance comes close to 90° . This applies equally to both the pan and tilt angles. As a rule of thumb, the range from -85° to -95° and $+85^\circ$ to $+95^\circ$ should not be used (always related to the setpoint plus set tolerance).

There is a similar problem with $\pm 180^\circ$. Here it is the reversal of the sign that is to be avoided. A programming of for example -160° with a tolerance $\pm 20^\circ$ would still be feasible. -160° with a tolerance $\pm 21^\circ$ should be avoided. This problem also affects both the pan and tilt angles.

15 Mounting on trusses or other constructions

When mounting the Flame Heads in particular on trusses or other similar constructions, the units must be secured with additional measures against falling. For this purpose, observe the applicable regulations of the employers' liability insurance associations for places of public assembly.

Safety ropes or belts should be attached to a very stable eyelet, which can be inserted into the guides on the housing of the Flame Heads by means of sliding blocks. The ropes or straps should be almost slightly stretched tight to ensure that the fastener cannot be pulled out.

In addition, the carrying handle of the Flame Head can also be used for fastening, although this should never be used as the sole safety fastener because the threads can break off.

The user must ensure that any fallout does not endanger the audience or cause panic in the audience.

16 Truss mounting plate for the L-Flame Flame Head

With a separately available truss mounting plate, the Flame Head can be mounted more easily on or to 400 mm truss systems.

The plate is attached to the underside of the Flame Head. First, insert both bolts of the unit through the holes in the mounting plate. Then secure the plate with the two flip pins provided.

Now half cones can be screwed in, which can then be inserted into the truss ends. Alternatively, mounting clamps can also be installed.

17 'Flying' the L-Flame Pump Station (mounting above the audience)

The 'flying' installation of the Pump Station, i.e. hanging on ropes or belts, is not actually intended and should only be carried out in justified exceptional cases. The user alone is liable for this application and therefore no special warnings have been included in this document. This type of installation is strongly discouraged in any case.

In this context, it is absolutely essential that the Pump Station is always operated only horizontally to ensure that the liquid sensor in the tray reliably detects escaping fuel as a leak and automatically depressurizes the system (Fail Safe). Ensuring this is very challenging.

Otherwise, there is a risk that large quantities of fuel are released in an uncontrolled manner with serious consequences such as fires and personal injury.

It may be easier to ensure this if the unit is placed on a stable and level platform instead.

In any case, the unit must be secured with safety ropes or belts to prevent it from falling. Please observe the applicable regulations of the employers' liability insurance associations for places of public assembly.

18 Additional requirements for fixed installations

If the system is permanently installed, it must be ensured that it is monitored by suitable personnel just as intensively as in the case of a temporary installation.

If required, automated monitoring functions should be discussed with the manufacturer to find a good solution. For example, it is possible to use liquid, pressure and flow sensors to automatically detect the unwanted release of fuel and issue an alarm.

The amount of fuel held in storage and in the Pump Station should be as low as possible.

TIP	Expect that the L-Flame Flame Heads generate a flame every time you trigger the device even if there is no fuel supply. It could be that there is still fuel in the system and due to that a flame can be possibly generated. Furthermore, it could be that the system has not been completely emptied last time when the devices have been used.
------------	---

19 Fuel consumption and flame heights

With a small nozzle with an inner diameter of 1.3 mm and a pressure of 13 bar: 70 ml / second and Flame Head. A flame height of approx. 10 m is achieved.

With a maximum usable tank capacity of 17.5 L, this results in approx. 250 seconds total flame duration with one Flame Head, 125 seconds if two Flame Heads always fire simultaneously and 83 seconds if three Flame Heads always fire simultaneously.

With a large nozzle with an inner diameter of 2.3 mm and a pressure of 18 bar: 190 ml / second and Flame Head. A flame height of approx. 15 m is achieved.

With a maximum usable tank capacity of 17.5 L, this results in approx. 92 seconds total flame duration with one Flame Head, 46 seconds if two Flame Heads always fire simultaneously and 25 seconds if three Flame Heads always fire simultaneously.

A negative hysteresis of 1.5 bar is recommended.

20 Operating range per battery charge

A fully charged battery in the Pump Station can pressurize approximately five times the tank's capacity, deliver it to the Flame Heads, and atomize and ignite it by means of three Flame Heads.

21 Switching on the Pump Station and meaning of the standard displays in the normal mode

Before you switch on the device, you must ensure that an emergency off button is connected and that it is not actuated. Otherwise, the unit would go to "Fail Safe" immediately upon power up. Fail Safe would be a safe condition where no pumping operation is possible.

Now operate the main switch and move it to the "On" position.

The display first shows the start message and the software version:

Galaxis
PYROTEC

L-Flame Pump
Station VX.XXX

During the start-up process, an LED test is performed.

If the system is under pressure, the Pump Station will automatically discharge it.

Depressurize...

This process takes a few seconds.

If the tank is overfilled, the pressure discharge will be blocked to prevent fuel from being forced through the pressure relief valve into the unit's tray. In this case, you will see the following message:

Tank too full,
no depressurize!

In this case, you should pump fuel out of the tank. You can achieve this with the corresponding menu item.

After the start-up process, the device changes to normal mode and you can now call up the menu by activating 'Mode'. For example, you will see this first standard display:

SV: 17,0 bar; CO
AV: 0,0 bar; P0

'SV' stands for setpoint value of the pressure. You can adjust this setpoint in the menu. 'AV' Means actual value. Here the device continuously measures the actual pressure and displays it.

'bar' is the displayed pressure unit. Here psi or bar can be selected in the menu. 'CO' means the pressure control is switched off. 'P0' means the pumps are currently off.

Later, when you have activated the pressure control, you will see 'C1' in the display. Depending on whether the pumps are currently on or off, either 'P0' for 'Pumps off' or 'P1' for 'Pumps on' is shown. The pumps can only be switched on if the pressure control is on.

Use 'Up' and 'Down' to navigate between the following standard displays:

Level: ?%,
not measured

As long as the fuel level in the tank has not yet been measured, you will see this display. Otherwise, you will see the result of the last level measurement instead.

Head Status:
H1:x, H2:x, H3:x

It is planned that the Flame Heads transmit information about their status to the Pump Station. With this firmware version this is not yet possible and you will see this placeholder display.

Faults:
none

If faults are detected, they will be displayed here.

You can access the menu from any standard display.

22 Switching on the Flame Heads and safety timer

The Flame Heads are turned on by moving the main switch on the Pump Station to the 'on' position.

<p>WARNING</p>  <p>2.2.2 2.3.4 2.4.2</p>	<p>Unintentional triggering of a flame column</p> <p>Technical faults can lead to unintentional flame effects.</p> <ul style="list-style-type: none"> • Make sure that the required safety distance to persons is maintained. • Only connect the fuel-carrying lines when they the device is switched off. • Minimize the presence in the danger zone. • Enable the flame monitoring system. • Never keep body parts above the combustion chamber at any time. • Follow all safety instructions and regulations at all times.
--	--

If applicable, the following startup messages are displayed immediately after the firmware version is displayed:

**Rel. Humidity in
the Device: 36%**

If the relative humidity in the device exceeds 30%, you will see this message. Have the desiccant replaced or carry out the replacement of the desiccant yourself.

**Flame Quota /
Flame Duration**

If either a flame quota or a flame duration limit is active, you will see the displays shown on the left in the LCD one after the other.

activated!

**Memory
Maintenance 50%**

After every 50th switch-on of the device, a so-called memory maintenance is performed to ensure correct functioning of the device even after many years. Please wait until the progress indicator shows 100% and do not switch off the device under any circumstances. After that, the startup process will continue as usual.

**Battery voltage
too low!**

In this case, the Pump Station battery is probably heavily discharged. Charge it completely before starting up the system again.

**Operation on 5V
mains adapter**

In this case, you can call up the menus and also communicate by radio. When triggering flame effects, neither ignition sparks are generated nor magnetic valves are opened, because there is no power supply with 12V DC is available. There is a separate chapter on this subject in this manual.

Messages warning of a danger are preceded by this display:

ATTENTION!

At the same time, you will hear a warning tone if the loudspeaker is switched on. Immediately after this, the warning indications are displayed as far as applicable.

Possible warning messages are:

**Flame Sensor
Disabled!**

There is a risk of unburned fuel being released because the fuel valves are not closed quickly in the event of an ignition failure.

**Tilt Switch
Disabled!**

The tilt switch has been deactivated. There is a risk that the fuel supply will not be closed if the unit falls over or is tilted.

**3D Tilt Sensor
Disabled!**

The 3D tilt sensor system has been deactivated. There is a risk that the fuel supply will not be closed if the unit falls over or is tilted or its inclination is changed.

**Warning LED
Disabled!**

Persons may not be warned of imminent flame effects.

After the firmware version and any startup messages are displayed, the safety timer occurs, which lasts 15 seconds:

**Safety Timer
Armed in: 15s**

The timer counts down 15 seconds.

The purpose of the safety timer is that the user can step back from the device before a flame effect can be initiated.

The safety timer will be started no matter which control method has been selected.

TIP

While the safety timer is counting down you can terminate the sequence and directly invoke the menu by activating 'Mode'.

Immediately after switching on and the expiry of the safety timer, the device switches to receive or standby mode. Only in this operating mode can flame effects be generated and bidirectional remote access take place. If communication takes place via radio, it can be referred to as the receiving mode. Otherwise, it is the standby mode.

23 Automatic checks during startup of the Flame Head

As soon as you switch on the device, a check of the components for correct function takes place during the startup sequence. If an error has been detected you see the following on the screen:

ACHTUNG!
ATTENTION!

A detailed error message is subsequently displayed. The error messages that may occur are explained in the following sections.

23.1 The error message '#'

#

An error has been detected in the configuration of the device, which is why it has been locked. Unlocking can only be performed with telephone assistance and during business hours by our support.

To initiate the unlocking process, activate 'Up' once when this message is displayed and then activate 'Down'.

The following scrolling text is then displayed:

Call the Galaxis office and tell the token. You will receive the activation code. Continue with Mode.

If you now activate 'Mode' a random eight-digit sequence of numbers will be generated and displayed, the so-called token. Tell us this token on the phone and will give you the corresponding activation code.

TIP

You may speed up the ticker by activating the 'Mode' sensor field and keeping it activated.

The sequence is as follows:

Token:
53582820

Example of a token being displayed. This screen is being displayed sufficiently long so that you can tell us the token on the phone.

Code?



Then you see this request to enter the activation code which you will receive from Galaxis on the phone. With 'Up' and 'Down' you can change the digits. If you see the correct number being displayed activate 'Mode' to proceed. A '0' can be entered the easiest by activating 'Mode' without activating 'Up' or 'Down' before.

Code? OK
44232502

The activation code, which has also eight digits, has been accepted and the device is unlocked.

Code? X
5423250200

A wrong activation code has been entered and the code was not accepted. Switch off the L-Flame Flame Head and repeat the procedure.

23.2 The error message 'ATTENTION! Flame Sensor ERROR'

Flame Sensor
ERROR

The flame sensor incorrectly signals a flame although no flame generation is taking place. Please contact us when this error message is displayed in order to perform an error analysis.

23.3 The error message 'Radio Module not detected'

Radio module not
detected!

The radio option was activated in the menu of the device, but no radio module was detected. Please check the correct installation of the Advanced radio module as described in item 'Software installation of the Advanced radio module'. If this error message occurs again, please contact us to perform an error analysis.

23.4 The error message 'Memory Error!'

Memory Error!
Code 1

The device has detected an implausible value in the non-volatile data memory, which is why safe operation cannot be guaranteed. In any case, please check all relevant settings and make corrections if necessary to bring the device back to an operational state. Then test the device for correct function.

The repeated display of this error message indicates a defective memory chip. Please contact us to discuss the further procedure and tell us the displayed error code.

23.5 The error message 'Firmware Mismatch'

Firmware
Mismatch

This error message indicates that there is an internal communication error between the microcontrollers installed in the L-Flame Flame Head. Immediately after this message is displayed, the text below appears.

Device Locked.
Call Support!

This error usually occurs when a firmware update was performed by the user and failed. In this case, repeat the update and contact our support for this.

23.6 The message 'Memory Maintenance'

Memory
Maintenance 50%

After every 50th switch-on of the device, a so-called memory maintenance is performed to ensure correct functioning of the device even after many years. Please wait until the progress indicator shows 100% and do not switch off the device under any circumstances. After that, the startup process will continue as usual.

23.7 Double assignment of DMX channels

Identical DMX
Channels!

The device checks whether there is a possible double assignment of the DMX channels. This is not allowed. In this case you will see this display and shortly afterwards you will be forced to set the values for the flame and the safety channel. Set different DMX channels in this menu.

24 Manual hardware checks with startup of the Flame Head

Your device supports a series of hardware tests that you can call up conveniently via a menu. Thereby you have the possibility to check all safety relevant components separately for their correct function. To call up the menu, activate 'Mode' when the device is switched off and switch the device on. Activate 'Mode' several times until the following display appears.

24.1 Checking the fuel valves for correct function

Your unit has two fuel valves connected in series. You have the option of controlling both fuel valves separately from each other. This test has been implemented in order to check both valves if they open and close well. You can hear a sound each time the piston in the valve is moving.

Magnetic Valve 1
Closed

Activate 'Up' to open the first fuel valve.

Magnetic Valve 1
Open 04:59

As soon as the fuel valve has been opened, you will see the display opposite. You can now close the fuel valve immediately by activating 'Down', or you can wait for the countdown until it closes automatically. You can reset the countdown to the start time of 05:00 minutes at any time by activating 'Up' again.

To end the test of the first fuel valve, activate 'Mode'. You will now be taken to the next screen to control the second fuel valve. The menu navigation is identical to that for the first fuel valve. Activate 'Mode' again to end the test.

24.2 Checking the ignition spark generators for correct function

As soon as you have finished the test of the second fuel valve with 'Mode', the menu for testing the ignition spark generators is displayed.

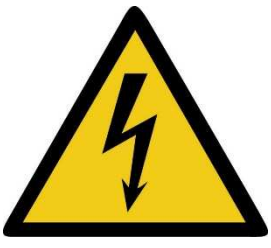
<p>WARNING</p>  <p>2.3.3</p>	<p>High voltage at the ignition electrodes</p> <p>For the operation of the electrical ignition of the fuel a very high voltage is generated in the device, which can be life-threatening.</p> <p>Never touch the ignition electrodes during operation.</p>
--	---

↑: Test Spark [Ω]

Activate 'Up' to generate the ignition sparks.

↑: Test Spark [Ω]
A: 6.25, B: 6.67

The ignition spark is now generated for two seconds. During this time, you can hear a distinct buzzing sound, as well as you can see two ignition sparks at the electrodes. At the same time, you will hear a regular clicking sound. With each click, the resistance of the ignition coils is measured and displayed.

If you do not get audible or visual feedback, start the test again from the beginning. If this test also fails, a defect must be assumed. In this case, please contact us in order to carry out a fault analysis.

Activate 'Mode' in order to continue the next menu item.

24.3 Check flame sensor

F-Sensor, †=LSP
≡

The flame sensor works optically. You see this display. In the bottom line you see a symbol which moves to the left or right. The sensor can be tested really easily with a small flame such as from a lighter. To do

this, slowly approach the flame to the measuring window and then remove it again (distance at the beginning approx. 20 cm). While you are approaching the flame, the symbol must move clearly to the right. When you remove the flame again, the symbol must move strongly to the left.

The sensor works differentially. This means that the deflection decreases when the flame remains close for a longer period of time. If the flame then extinguishes or is removed, the deflection is even more significant in the opposite direction.

The "Up" and "Down" keys can be used to output an acoustic signal instead of the symbol on the LCD or to switch back to the display of the symbol. The frequency of the acoustic signal must increase when the flame is approached. Reversely, the frequency must decrease when the distance of the flame increases.

Activate 'Mode' to exit the test menu and continue the startup process.

25 Battery monitoring and warning message 'deep discharge' after powering up the device

The rechargeable battery of the Pump Station is monitored during operation. If the battery is being deeply discharged while the device is in normal mode this event is stored in the memory of the device and each time when you switch on the device you will see a warning message.

TIP

Deep discharges can only be detected if the device is in normal mode.

In case of a deeply discharged battery, you see e.g. this being displayed and during that an acoustic signal will be given:

Batt. 1x deeply
discharged

The number of deep discharges is being displayed here.

Please have the battery checked by the manufacturer and replaced if necessary.

Please note that deep discharges generally lead to reduced battery life.

26 Measuring the fuel tank level

From any standard display in normal mode, you can measure the level of fuel in the tank and display the measured value.

To do this, actuate the magnetic sensor next to the LED bar display for the filling level.

You will first briefly see this indication in the display:

Ventilate tank,
please wait...

The level is measured with a sensitive pressure sensor that detects the height of the liquid column in the tank. For correct operation, it is necessary that the tank is depressurized. Due to temperature and air pressure differences or pumping operation, there may be under- or overpressure in the tank. This pressure can be discharged by opening a vent valve. The process takes only a moment. Meanwhile, you will see a fast running light on the LED bar display at the top of the device.

The device then measures the level in cycles. A short beep is emitted with each measurement.

You will see this display in the LCD, for example:

Level: 68%,
146mm, 11,9L

At the same time, the filling level is also displayed on the LED bar on the top of the device.

Instead of metric units, you can also display Anglo-American units here, provided you have selected them in the menu items available for this purpose. Instead of bar, psi can be displayed. Instead of mm, inches can also be shown, and instead of liters, the filling level can be displayed in US liquid gallons.

Assuming you would now fill in additional fuel, you could also read the increasing fill level on the displays.

If you do nothing else, the device automatically ends the cyclical level measurement after approx. five minutes.

The standard level display now shows the last measured value and no longer "Level not measured."

You can start a new level measurement at any time to get a current value.

In pump mode, the instrument automatically measures the level and updates the displayed values as soon as the pumps have been running for at least two seconds. This time is necessary so that the pressure equalization between tank pressure and the ambient atmospheric pressure could take place.

27 The menus of the L-Flame Pump Station

You can access the main menu by activating "Mode" with the magnetic pen for a longer time during the standard displays in normal mode.

27.1 The main menu of the Pump Station

27.1.1 The menu item 'Language'

Sprache/Language
Deutsch

Here you can select the language of the operating menu and the displays. German and English are available for selection. Activating 'Mode' takes you to the next menu item.

27.1.2 The menu item 'Accumulator capacity'

For example, you can see this display:

Accumulator
Capacity: 95%

In this example the remaining charging level is 95%. If the value decreases below 30% the charging reserve is being touched. If the battery is being discharged to 0% damages due to deep discharging are possible.

TIP	The display of the accumulator capacity is related to an ambient temperature of 20°C. A fully charged battery could also lead to a reading of e.g. 80% if the temperature is very low.
------------	--

No result regarding the accumulator capacity can be acquired as long as the battery is being charged. In this case you will see the following information in the display:

The accumulator
is being charged

The results may be higher directly after charging. We recommend to wait an operation time of approx. 10 minutes to gain realistic results.

TIP	The power consumption of the pumps of the device is very high. Therefore, it is best to always charge the device when it is in use. At the latest when only a charge level of 50% is displayed, you should connect the charger.
------------	---

TIP	The menu item 'Accumulator Power' does not exist in this device for technical reasons because the battery is extremely large.
------------	---

27.1.3 The query 'Call Submenu?'

You can reach this query by activating 'Mode':

Enter |✓
Submenu? |X

Enter the submenu by activating 'Up'. 'Down' and 'Mode' takes you to the next main menu item. The submenu is described in a separate section.

27.1.4 The menu item 'Setpoint Value'

Here you can enter the pressure setpoint. This device uses a so-called on-off pressure control, also known as two-step or bang-bang pressure control. The pumps are switched on when the pressure falls below a certain value and switched off again when the pressure exceeds another value. The difference between these two values is called hysteresis. A hysteresis is useful so that the pumps are not switched on and off again too quickly one after the other.

Setpoint Value:
17↕bar

Here you can set the setpoint value of the pressure control. As soon as this value is reached, the pumps are switched off automatically. The setting range is 3 to 19 bar in steps of 1 bar (44 to 275 psi in steps of 1 psi).

You should not set the setpoint too high. The pumps will reach a maximum of about 19-20 bar (276 to 290 psi) when the battery is full. When the battery is empty, somewhat less.

However, the set point must not be too low either, or the fuel will not be atomized well and the accumulators in the Pump Station and Flame Head will not be able to operate properly. Unwanted fallout would be the result.

Quite low values can also be set in this menu item. However, these are only for low flame nozzles that may be available in the future. These low values are only adjustable to be prepared for all cases and to avoid firmware updates only because of the pressure setting range.

A value of approximately 17 to 18 bar (247 to 261 psi) has proven to be effective for the set point.

The device saves this parameter when you exit the menu item.

27.1.5 The menu item 'Negative Hysteresis':

Here you can set the hysteresis. You will see the following display, for example:

Neg. Hysteresis: 1.2 bar

Here you can set the hysteresis. You will see e.g. the following in the display: In this example, the hysteresis is 1.2 bar. The hysteresis can be set in steps of 0.1 bar (1 psi). The setting range starts at 0.1 bar (1 psi) and ends at 2.5 bar (36 psi).

The hysteresis determines at which pressure the pumps are switched on. It is to be understood as a differential pressure specification and acts downwards, which is why we chose the designation 'negative hysteresis'.

An example: Assuming a setpoint of 17.5 bar and a negative hysteresis of 1.2 bar. Then the pumps are switched off when 17.5 bar is reached. At some point the pressure drops again, e.g. due to consumption. Then the pumps are switched on again when the pressure falls below the setpoint minus the hysteresis, i.e. 17.5 bar minus 1.2 bar. So exactly at 16.3 bar.

An on-off control always works with a hysteresis. In our case, this means that the pumps are not switched on and off very quickly one after the other. This would be inefficient and would greatly reduce the lifetime of the pumps.

A value of approx. 1.5 bar has proven to be suitable for the negative hysteresis. The hysteresis should not be too large, because otherwise the pressure will become too low in the meantime and the fuel can no longer be atomized properly by the nozzles in the Flame Heads.

This parameter is saved and is then set in this way from this point on.

27.1.6 The menu item 'Pressurize system?':

Pressurize system?	✓
	X

Now you are asked whether the system pressure should be built up after leaving the menu.

With 'Up' you enter 'Yes'. 'Down' and 'Mode' mean 'No'.

If you now exit the menu, you will see the standard display of the normal mode.

If you have switched on the pressure control, then 'C1' for 'Control on' and 'P1' for 'Pump on' should be displayed. In addition, the measured actual pressure value should increase until the setpoint is reached. If this is the case, you will see 'P0' in the display because the pumps are turned off. It is normal that fuel now flows into the Flame Heads and is pumped several times until the same pressure is reached everywhere.

<p>WARNING</p>  <p>1.5</p>	<p>Leakage</p> <p>Fuel-carrying lines can leak.</p> <ul style="list-style-type: none"> • Check connections for leaks. • Follow all instructions in the operating manual regarding maintenance. • Do not use the device if leaks are detected. • Follow all safety instructions and regulations at all times.
--	---

<p>WARNING</p> 	<p>Explosion hazard, fire hazard</p> <p>Explosion of vapors, ignition of fuel.</p> <ul style="list-style-type: none"> • During operation, the tank is partially ventilated. • Therefore, keep ignition sources away from the 'Tank Vent' opening. • Fuel may be released during certain menu items. Keep ignition sources away from a large area. • Observe all safety rules and regulations at all times.
---	---

27.2 The submenu of the L-Flame Pump Station

When you enter the submenu, the first thing you will see is the following menu item:

27.2.1 DMX512 and RS485 Routing

DMX512 is the widely used protocol for controlling lighting equipment. It is transmitted on a RS485 interface. The RS485 standard defines how this interface works in terms of hardware and which network topology must be used.

The DMX signal fed to the pump station is routed to the first flame head and back to the pump station. Then to flame head 2 and back. Then to the third head and back. Then it is available again at the DMX output of the pump station and can be routed to the next DMX device.

This signal routing is necessary because a linear network topology is mandatory for the RS485 interface.

It is also important to know that only the flame heads and not the pump stations decode DMX. Therefore, it is not possible to set DMX channels for the pump station.

It should also be mentioned that instead of DMX512, wired communication between a PFC Advanced and the Flame Heads is also possible via this interface. Therefore we speak of "DMX512 and RS485 Routing" and not only of "DMX512 Routing".

The Flame Heads must be connected in order starting with Head 1. It is therefore not possible, for example, to operate Flame Heads only at ports 2 and 3 and no Flame Head at port 1.

The following settings are possible with this menu item:

DMX/RS485 Route:
In→H1→H2→H3→Out↕

The signal reaches all Flame Heads one after the other.

DMX/RS485 Route:
In→H1→Out ↕

Here, only the first Flame Head receives the signal. Use this variant if you operate only one Flame Head at the Pump Station.

DMX/RS485 Route:
In→H1→H2→Out ↕

Here, the signal reaches Flame Head 1 first and then also Flame Head 2. Use this setting when two Flame Heads are to be operated.

In all cases the signal is available again at the output at the Pump Station, provided that the heads are connected as set in the menu item. The signal can be routed to another Pump Station or any other DMX device.

27.2.2 The menu item 'Power Supply for Wi-DMX'

Sometimes the autarkic operation is an important aspect in the practical usage of the L-Flame. Besides the Advanced wireless module which enables the wireless communication between the device and a Galaxis controller or the wireless USB modem PFM Advanced you may also use wireless DMX solutions, either as an additional option or exclusively.

Here, it is a major disadvantage if DMX receivers as a desktop device offer wireless communication but require first of all a wall power supply and mains power and secondly a cable connection to the L-Flame Pump Station in order to feed in the DMX signal.

Due to that various manufacturers offer wireless DMX Pens, which can simply directly be plugged into the jacks for the DMX signal. The L-Flame Pump Station has been equipped with the necessary hardware to supply power to these DMX Pens so that no additional power source is required and autarkic operation becomes possible also this way.

With this menu item you can switch the power supply for these DMX Pens either on or off:

Power Supply for Wi-DMX:	Off
-----------------------------	-----

There is no voltage output with this setting.

Power Supply for Wi-DMX:	On
-----------------------------	----

With this setting +5VDC on Pin4 and ground (0V) on Pin5 will be applied.

The DMX receivers must be connected to the 5-pin XLR socket.

All DMX Pens can be used that need a supply voltage of 5V and not more than 700 mA.

TIP

The DMX pens offered have a certain power requirement. This reduces the battery runtime somewhat. However, the battery of the Pump Station is very large, so that there are still long operating times.

TIP

For best reception during wireless DMX operation you should not directly plug in the DMX Pens. Instead use a short DMX cable to operate the DMX pens in some distance. You can for example use some Gaffa tape to fix the DMX Pens on the side of the housing so that the antenna is pointing upwards and reception is not impaired.

27.2.3 The menu item 'Acoustic Signals'

This menu item switches the acoustic signals of the device on or off. Beep tones etc. may be disturbing on theatre stages and in this case, it is meaningful to disable the sounds.

Please note that there will be no acoustic signals at all if the sounds are turned off, even no warning signal if the battery needs recharging or any other even more critical alarms.

Acoustic Signals:	On
----------------------	----

In this example the acoustic signals are enabled.

27.2.4 The menu item 'LCD Backlight'

This text for example is being displayed:

LCD Backlight: auto & dimmed

The display backlight is turned on automatically as soon as the menu is called up or messages are being displayed. The display is illuminated slightly (dimmed) in all other cases. That enables you to read the display

content in darkness without any further action required. The power consumption for this slight permanent illumination is negligible.

LCD Backlight:
auto & off

If you choose this setting the display backlight is completely turned off as soon as the device is not in the menu or if there is no message. This is preferable in some applications where the slight illumination of the display could be disturbing.

LCD Backlight:
always off

With this setting the display backlight is off all the time.

27.2.5 The menu item 'Pressure Unit'

Here you can define in which unit pressures are displayed and entered.

Pressure Unit:
bar

The options are bar or psi. Use the unit with which you are more familiar. Technically, it makes no difference which unit is used.

Pressure Unit:
psi

Here psi has been selected as the pressure unit. 1 bar corresponds to 14.5 psi. 1 psi equals 0.069 bar.

27.2.6 The menu item 'Depth Unit'

Here you can define in which unit of depth the level of the tank is displayed.

Depth Unit:
mm

The available choices are mm or inch. Use the unit with which you are more familiar. Technically, it makes no difference which unit is used.

Depth Unit:
inch

Here, inch was specified as the unit of depth. 1 mm corresponds to 0.0394 inch. 1 inch is equivalent to 25.4 mm.

27.2.7 The menu item 'Volume Unit'

Here you can define in which volume unit the filling amount of the tank is displayed.

Volume Unit:
Liter

The options are liters or US liquid gallon. Use the unit with which you are more familiar. Technically, it makes no difference which unit is used.

Volume Unit:
US liq. gallon

Here, US liquid gallon was specified as the unit of volume. 1 liter is equal to 0.2642 US liquid gallon. 1 US liquid gallon is the same as 3.7854 liters.

27.2.8 The menu item 'Pump out tank?'

This menu item offers you the possibility of emptying the tank, for example if a transport is imminent, without having to tilt the device for this.

<p>WARNING</p> 	<p>Explosion hazard, fire hazard</p> <p>Explosion of vapors, ignition of fuel.</p> <ul style="list-style-type: none"> • During operation, the tank is partially ventilated. • Therefore, keep ignition sources away from the 'Tank Vent' opening. • Fuel may be released during certain menu items. Keep ignition sources away from a large area. • Observe all safety rules and regulations at all times.
---	---

First, make sure that the battery is sufficiently charged.

It is also very important that the device is level. Therefore, check whether the bubble level on the top of the device indicates that the device is level and correct this if necessary.

Connect a suitable hose to the 'Empty Tank' connection piece and make sure that it is firmly attached.

Insert the other end of the hose into a container, such as a canister, which has enough capacity to completely collect the fuel. Make sure that the end of the hose always remains in the container and is not lying around openly.

At the beginning of this menu item, you will see this display in the LCD:

```
Pump out   |✓
tank?     |X
```

If you want to pump out the tank, activate 'Up'. 'Mode' and 'Down' gets you to the next menu item.

```
Ventilate tank,
please wait...
```

If you have selected the 'Pump out tank' function, this display appears for a short moment while the tank is being ventilated. This pressure compensation is necessary on the one hand so that the device can measure the filling level and on the other hand so that air can flow into the tank when the pumps are in operation.

Now there is a scrolling text display with this content:

```
Attention! Put hose into canister and connect it at
'Empty Tank'. ↑ = Pump On, ↓ = Pump Off, Mode = Exit
```

TIP

If you are familiar with the scrolling text, you can speed it up by activating 'Mode'.

You will then see this display:

```
Pump: Off   |✓
Level: 86%  |X
```

The pump is always switched off at the beginning and the device continuously measures the level in the tank and displays it as a percentage value. By activating 'Up' you switch on the pump.

```
Pumpe: On   |✓
Level: 82%  |X
```

The pump has been switched on here. Fuel is pumped out. The filling level decreases. To stop pumping, you must actuate 'Down'. You can switch the pump on again at any time.

```
Minimum level of
<= 4% reached!
```

When the tank is almost empty, this menu item is automatically terminated and you will see this display.

With 'Mode' a possibly switched on pump is also switched off and you cancel this menu item and reach the next menu item.

Pumping out a full tank takes approx. four minutes.

If you do nothing, the device ends this menu item automatically after five minutes and you reach the next menu item.

To empty the tank completely, you must drain the fuel by opening the drain plug and allowing the fuel to drain into a container.

27.2.9 The menu item 'Vent and back-flush?'

This menu item is used to flush the internal hydraulic system of the Pump Station and to remove air from the piping and the pressure accumulator during initial start-up or after a longer downtime, so that less air reaches the Flame Heads.

It is not necessary to perform this function at every start-up.

<p>WARNING</p> 	<p>Explosion hazard, fire hazard</p> <p>Explosion of vapors, ignition of fuel.</p> <ul style="list-style-type: none"> • During operation, the tank is partially ventilated. • Therefore, keep ignition sources away from the 'Tank vent' opening. • Fuel may be released during certain menu items. Keep ignition sources away from a large area. • Observe all safety rules and regulations at all times.
--	---

You will see this query in the display:

Vent and back-flush | ✓
| X

With 'Up' you start the process. Use 'Down' or 'Mode' to go to the next menu item without starting the function.

Ventilate tank, please wait...

If you have selected the 'Vent and back-flush' function, this display appears for a brief moment while the tank is being vented. This pressure equalization is necessary on the one hand so that the device can measure the filling level and on the other hand so that air can flow into the tank when the pumps are in operation.

Venting and flushing-back...

You will see this display while the process is being executed. To stop the procedure, you can either turn off the device with the main switch or the emergency stop switch (E-Stop) to be connected to the device at any time.

Finished

The process has been completed successfully. After a few seconds, you will automatically be taken to the next menu item.

27.2.10 The menu item 'Start pump self-test?'

If you suspect that something is wrong with the pumps in the Pump Station, you can start this self-test to check the pumps.

It is especially important for this test that the battery is fully charged. If the battery does not have more than 50% charge, then you must first fully charge it before this test.

<p>WARNING</p> 	<p>Explosion hazard, fire hazard</p> <p>Explosion of vapors, ignition of fuel.</p> <ul style="list-style-type: none"> • During operation, the tank is partially ventilated. • Therefore, keep ignition sources away from the 'Tank vent' opening. • Fuel may be released during certain menu items. Keep ignition sources away from a large area. • Observe all safety rules and regulations at all times.
---	---

You will first see this dialog on the display:

```
Start pump   | ✓
self-test?  | X
```

With 'Up' you start the pump test. You can use 'Down' or 'Mode' to go to the next menu item without starting the process.

The unit has a total of six pumps. First, two pumps draw the fuel from the tank in parallel operation and reach a pressure of approx. 10 bar (145 psi). These pumps are designated No. 1 and No. 2. Each of these pumps is followed by two more pumps in parallel operation, which further increase the pressure up to about 20 bar (290 psi). These are the pumps with the numbers 3, 4, 5, and 6.

In the pump test, all pumps are now tested one after the other. The test starts with the two pumps that directly take in the fuel from the tank.

At the beginning of the test, you will see this display:

```
P123456
_____
```

'P123456' is the column label for pump 1 to 6. Below each digit you can see an underscore. The results for each pump are displayed here.

```
P123456  8,0 bar
_____  0,0 bar
```

The test begins. At the upper right, the required minimum pressure that the pump under test must reach is displayed. At the bottom right, you can see the pressure that the pump is currently delivering.

```
P123456  8,0 bar
_____  9,7 bar
```

Pump 1 delivers 9.7 bar. This is more than the minimum value. Pump 1 has therefore passed the test. Immediately afterwards, this is also indicated.

```
P123456  8,0 bar
✓_____ 10,2 bar
```

Pump 1 has passed the test. This is indicated by the check mark. Pump 2 is currently being tested. This pump is currently delivering 10.2 bar. This is also more than required.

```
P123456 17,0 bar
✓✓_____ 20,1 bar
```

Pump 1 and 2 have been tested successfully. The test of the third pump follows. Here, pump 1 and pump 3 are operated in series. Together they supply a pressure of just 20.1 bar, whereas at least 17.0 bar must be reached to pass the test.

```
P123456 17,0 bar
✓✓✓_____ 19,8 bar
```

Pumpe 1 bis 3 wurden erfolgreich getestet. Aktuell wird Pumpe 4 getestet. Diese läuft auch zusammen mit Pumpe 1 in Reihenschaltung. Insgesamt liefern diese beiden Pumpen 19,8 bar. Das ist auch genug, um den Test zu bestehen.

```
P123456 17,0 bar
✓✓✓✓_____ 19,6 bar
```

Pumps 1 to 3 have been tested successfully. Pump 4 is currently being measured. This also runs together with pump 1 in series connection. In total, these two pumps deliver 19.8 bar. This is also enough to pass the test.

```
P123456 17,0 bar
✓✓✓✓✓_____ 20,2 bar
```

Pumps 1 to 5 have already passed the test. Currently the test is running with pump 6 which is operated in series with pump 2. The total pressure is higher than required.

```
P123456 17,0 bar
✓✓✓✓✓✓_____ 20,1 bar
```

All pumps have passed the test. What follows this is the completion message.

```
Finished
All pumps OK
```

The device is only operational if you see this success message. If just one pump is not working properly, the performance is limited or the device no longer reaches the required pressure for proper operation.

Examples of possible error messages:

```
P123456 17,0 bar
✓✓✓✓✓X 9,3 bar
```

Pump 6 has failed in this example. Pumps 3 to 6 can cause a singular error. This means that only this one pump is displayed as defective in each case.

```
P123456 17,0 bar
X✓??✓✓ 9,2 bar
```

Pumps 1 and 2 always lead to subsequent faults in the event of a failure because they are the first pump in a series connection. In this example, pump 1 is defective. This means that pumps 3 and 4 cannot be tested at all. Therefore, a '?' is displayed here.

As soon as even one pump is defective, you will see this display at the end of the test:

```
Finished
Pump failure!
```

In this case, the device requires repair. Please contact the manufacturer.

If you have selected the pressure unit psi instead of bar, then all specifications and measurements are of course made in psi.

After the completion message, you will automatically be taken to the next menu item.

27.2.11 The menu item 'Leakage Monitoring in Pump Station'

Here you can decide whether the Pump Station should perform automatic leakage monitoring of the internal systems.

Basically, you should always switch on this monitoring. Switching it off only makes sense in the event of certain malfunctions in order to be able to continue operating the device. Only do this if instructed to do so by the manufacturer and take special care in such a case.

During leakage monitoring, the device measures the system pressure after a pumping operation. If this pressure drops below a certain value without any plausible consumption taking place, the device interprets this as a leakage. In such a case, the device will depressurize everything and go into a safe operating state, also called 'Fail Safe'.

```
Leakage Monitor-
ing in PS:      On
```

Here, the internal leakage monitoring in the Pump Station is active. For technical reasons, the respective Flame Head is always responsible for monitoring the hoses. See menu in the Flame Head.

```
Leakage Monitor-
ing in PS:      Off
```

Only in justified exceptional cases and only on the manufacturer's instruction and only with the greatest caution may the leakage monitoring be switched off as it is done here.

<p>WARNING</p>  <p>1.5</p>	<p>Leakage</p> <p>Fuel-carrying lines can leak.</p> <ul style="list-style-type: none"> • Check connections for leaks. • Follow all instructions in the operating manual regarding maintenance. • Do not use the device if leaks are detected. • Follow all safety instructions and regulations at all times.
--	---

The submenu ends after this menu item. You will therefore reach the main menu after this menu item.

28 The menu of the L-Flame Flame Head

28.1 The menu item 'Language'

Sprache/Language English

Here you can select the language of the operating menu and the displays. German and English are available for selection. With 'Mode' you reach the next menu item.

28.2 The menu item 'Reboot?'

This menu item was created to be able to reboot the L-Flame Flame Head without having to switch the L-Flame Pump Station off and on again. You can use it to force the restart directly on the L-Flame Flame Head. It would be very inconvenient if you always had to go to the L-Flame Pump Station for this reason.

The following actions can be performed during a reboot:

- Take over the System ID from a PFS Profi*.
- Specify Defaults
- Set to Defaults
- Perform partial reset*
- Perform complete reset*
- Deactivate/activate radio option*
- Call configuration menu (service menu for production and repair)*
- Activate/deactivate flame options
- Perform field strength calibration
- Manual checks of hardware to be performed by customer

* without further description in this document since only on instruction by the manufacturer.

You see this screen:

Reboot?	Yes
	No

You restart the L-Flame Flame Head by activating 'Up'. With 'Down' or 'Mode' you reach the next menu item.

28.3 The menu item 'Accumulator Capacity'

You see e.g. this result in the display:

Accumulator
Capacity: 95%

In this example the remaining charging level is 95%. If the value decreases below 30% the charging reserve is being touched. If the battery is being discharged to 0% damages due to deep discharging are possible.

TIP

The display of the accumulator capacity is related to an ambient temperature of 20°C. A fully charged battery could also lead to a reading of e.g. 80% if the temperature is very low.

TIP

The result of this menu item can also be displayed at the controller PFC Advanced by using the function 'Remote data request'

No result regarding the accumulator capacity can be acquired as long as the battery is being charged. In this case you will see the following information in the display:

The accumulator
is being charged

The results may be higher directly after charging. We recommend to wait an operation time of approx. 10 minutes to gain realistic results.

28.4 The menu item 'Input'

In this menu item you can select one of the following control methods by activating 'Up' and 'Down':

Input: DMX512

Use this selection for operation with DMX512. In the Pump Station menu you can additionally define whether wireless DMX pens should be powered or not.

Input: Cable
(RS485 of PFC)

Use this selection if you want to use the L-Flame Flame Heads in conjunction with a PFC Advanced and if serial data cables should be used for the communication. 'RS485' is the cable interface of the controller PFC

Advanced. RS485 is the name of the technical standard of the interface being used here for the serial data communication between devices on data cables.

Input: Wireless
(PFC, PFS, PFM)

Use this selection if you want to use the L-Flame Flame Heads in conjunction with a PFC Advanced, PFS Profi or a PFS Profi or the wireless USB modem PFM Advanced and if the wireless link should be used.

TIP

The feedback information during remote data requests and programming will always be sent on both data exchange carriers: by radio signal and on the cable. You may select which way you want to use for the feedback in the menu of the controller PFC.

28.5 Menu items if DMX512 has been selected as an input

The following menu items are only being displayed if DMX has been selected as the input.

28.5.1 The menu item 'Flame Channel'

Flame Channel:
001

With 'Up' and 'Down' you can select a DMX channel ranging from 1 to 512 which should be used to control the flame effect. Confirm your selection with 'Mode'.

The functionality is described in detail in the chapters 'The DMX512 input and output' and 'Control via DMX512'.

28.5.2 The menu item 'Safety Channel'

In addition to the flame channel a so-called safety channel must be programmed.

Safety Channel:
013 60-80% = ✓

With 'Up' and 'Down' you can select a DMX channel ranging from 1 to 512 which should be used as the safety channel. Confirm your selection with 'Mode'. If you have for example 12 L-Flame Flame Heads in use it is meaningful to use the DMX channel 1 to 12 as control channels and the next DMX channel, in this case 13, as a safety channel on all devices.

Safety Channel:
013 60-80% = ✓

After the DMX channel has been selected, the value range for the dimmer value for the safety channel is now defined. The table below shows the configurations that are available for selection.

Safety range:	30-50%	40-60%	50-70%	60-80%	70-90%
Dimmer value decimal:	76-120	102-153	127-178	153-204	178-229

For the respective set safety range, corresponding dimmer values must be transmitted within the defined range so that a flame effect can be triggered.

The functionality is described in detail in the chapters 'The DMX512 input and output' and 'Control via DMX512'.

It is not permitted to use the same channel number for the flame and the safety channel. In this case the following will be displayed on the LCD:

Identical DMX
Channels!

This screen is being displayed for some seconds. After that the device jumps back to the menu item 'Flame Channel' so that different channels can be programmed.

You can only exit the menu if different channels have been selected.

28.6 Menu items if 'Cable (RS485 of PFC)' or 'Wireless (PFC, PFS or PFM)' has been selected as control method

The following menu items appear only if 'Cable (RS485 of PFC)' or 'Wireless (PFC, PFS or PFM)' has been selected as control method.

28.6.1 The menu item 'RF Channel' (i.e. frequency selection)

This menu item enables the user to determine which radio channel (RF = Radio Frequency) is being used by the device. If an Advanced wireless module is installed and configured in the EU version, you have the choice between 70 different frequencies (channel 0 to 69). If an Advanced wireless module is installed and configured in the US version, you have the choice between 360 different frequencies (channel 0 to 359). The particular frequency is being displayed in the bottom line.

The L-Flame Flame Head links the RF channel to the currently configured wireless module version (EU or US). Thus, two RF channels can be stored, one for EU and one for US. If you want to exchange the Advanced wireless module in the L-Flame Flame Head for another country version, you must also configure the currently installed Advanced wireless module in the menu and, if necessary, teach a new System ID or set a different RF channel. Read the notes in the section 'Configuration of the Advanced wireless module'.

RF Channel: 69 ↕
= 434.775 MHz

If you are changing the RF channel you will have to program all other devices to the new RF channel to ensure proper radio communication.

<p>WARNING</p>  <p>2.3.6</p>	<p>Unintentional triggering of flame effects when splitting Galaxis systems into two or more systems by the customer</p> <p>The simultaneous operation of systems that vary only in terms of different radio channels constitutes a safety risk.</p> <p>When two or more Galaxis systems are in use:</p> <ul style="list-style-type: none"> • Make sure that you have assigned different System IDs to the systems.
---	---

European Version (and also various other countries):

There are 70 different frequencies available between 433.0500 MHz and 434.7750 MHz in steps of 25 kHz. Normally you should use the frequency that has been assigned by the manufacturer and only switch to another channel if the selected frequency is occupied.

The frequency 433.9250 MHz (radio channel 35) and the two neighboring channels should not be used. This is a heavily used standard frequency and radio interferences are likely to occur.

In the countries Azerbaijan, Georgia and Russia the European harmonization standards have not been completely implemented so far. If you have an application in these countries, please ask the manufacturer or the appropriate authorities in the specific countries if a license exempt usage is possible or if you can apply for a license or if the usage is prohibited.

Other regulations may apply in non-European countries. Please ask the manufacturer if you need more information about the usage of frequencies. Most non-European countries allow the frequencies used by us. For customers in the USA and Canada we provide devices with a different frequency band. Please see 'Version for USA/Canada'.

Version for USA/Canada:

There are 360 different frequencies available between 458.0000 MHz and 462.4875 MHz with a channel spacing of 12.5 kHz.

You need to choose a frequency which allows nationwide use and which is exempt from any duties. More information can be obtained from frequency coordinators, the authority who is in charge of frequency allocation or the manufacturer. Even if the duty-free and nationwide usage of specific frequencies is possible, you have to register as user at the FCC before operating the devices. Upon your request we will provide the contact details of a competent frequency coordinator who will support you in this process.

Alternatively, you can apply for a license. In that case you will get a frequency assigned by a frequency coordinator. The disadvantage of a license is that the usage of the assigned frequency is only allowed in a certain region. You are allowed to use this frequency in a specific radius only. Every usage outside of this radius demands an additional license, except you are using a nationwide frequency (see above).

28.6.2 The menu item 'Interfering Signal'

This is the next menu item. You may see this being displayed:

Interfering Signal: 5%

The device is measuring and displaying the signal strength on the used radio frequency permanently as long as this menu item is present.

Normally this function is used to find out the cause of a radio interference. Values below 15% are uncritical. If the radio channel is busy you can select another frequency. Please see the section 'RF Channel' in this manual for further information.

TIP

The result of this menu item can also be displayed at the controller PFC Advanced by using the function 'Remote data request'.

TIP

You can use this menu item for a range test, too. Activate the firing mode at your controller PFS Profi, PFS Pocket or PFC Advanced. The device is now measuring the signal strength of your controller. By changing the location of the device you can try to find out which installation is best. You should definitely switch off the firing mode before you quit the menu and always make sure that there is no unintended activation of the firing button at the controller during the range test.

28.6.3 The menu item 'Last Range Test Result'

You will enter this menu item with another activation of 'Mode'. This function is mainly intended for users who are operating the transmitter PFS Profi or PFS Pocket. The new controller PFC Advanced is now offering the comfort of requesting the result of the range test remotely as well as the PFM Advanced USB Modem.

This function comes in handy if you do the set-up of the system without a helping person. After starting a range test at the transmitter, the L-Flame Flame Heads are displaying the results for approx. 10 seconds. Within this short period of time you cannot check the results of many different devices all over the place. This function enables you to ease this task.

Proceed this way:

- Switch on the L-Flames and start a range test at the controller.
- Go to each device, step through the menu and read the result which is being displayed under 'Last range test result'. This value has been displayed during the test.
- You can do another test if you like after reading all results.

Last Range Test
Result: ?%

If this display appears, it means that there is no range test result because it has already been read, or that the device was out of range of the transmitter at the time of the range test, or that no range test has taken place yet.

Last Range Test
Result: 65%

In this example the signal level at this L-Flame Flame Head was 65%. Values below 30% are critical.

TIP

The result is being cleared after stepping through the menu to ensure that the same result is not being displayed again after the next range test although the device is possibly out of reach. If you are using this function it is essential to read all the old results before starting a new test to make sure that they are all being cleared!

28.6.4 The menu item 'Device ID Number'

Dev. ID No. for
bidir. Comm.: -

This is the next menu item in the menu. A device ID number ranging from 1 to 999 can be programmed here. The device ID number is used as an identification address during bi-directional remote access. If no device ID number has been programmed the device cannot be accessed from the controller PFC during remote data requests and programming. Normally the devices are programmed with ID numbers in consecutive order. It is not allowed to program the same ID number to more than one device.

Dev. ID No. for
bidir. Comm.: 15

Here the Device ID Number 15 has been assigned to this device.

28.6.5 The menu item 'Determine Hazard Zone'

Determine
Hazard Zone: A✓

Here you can change the hazard zone of the L-Flame Flame Head. The default zone setting is hazard zone A. The check symbol indicates that the hazard zone is active, i.e. the device processes firing commands and generates flames according to the cue programming.

Determine
Hazard Zone: E✓

You may use up to 16 different hazard zone. These hazard zones are represented by the letters A to P. In this example the device has been assigned to the hazard zone E.

TIP

If you change the hazard zone in the menu the status is 'active' by default. Thus, firing commands will be processed and flame effects will be generated. If a specific hazard zone has been deactivated and you select another zone in the menu for the time being and then select the previous hazard zone this zone will be activated by doing so. The 16 hazard zones can be deactivated and also activated again according to your requirements in the manual and automatic firing mode of the controller PFC Advanced. For this please read the user manual of the controller PFC Advanced.

In the manual and automatic firing modes of the PFC Advanced controller, the 16 different hazard zones can be deactivated and also reactivated as required. Please refer to the operating instructions of the PFC Advanced controller.

The hazard zone which is currently assigned to the device and its status is being displayed in the receiving mode. You see e.g. this being displayed on the L-Flame Flame Head's LCD:

The hazard zone which is currently assigned to the device and its status is being displayed in the receiving mode. You see e.g. this being displayed on the LCD of the L-Flame Flame Head:

Firing Mode: Off
Hazard Zone: G✓

In this example the hazard zone 'G' has been assigned to device. The hazard zone is active.

Zündmodus: Aus
Gefahrenzone: GX

The symbol 'X' right next to the hazard zone indicates that this hazard zone has been deactivated. Flame effects are suppressed until this hazard zone is activated again.

TIP

The status of the device's hazard zone is always active after switching the L-Flame Flame Head on. Due to that firing commands will be allowed. We assume that all hazard zones should be active after powering all devices up so that only those hazard zones need to be deactivated which bear a risk in terms of safety.

TIP

When you enable or disable hazard zones at the controller the L-Flame Flame Head displays the current status of the hazard zone right after receiving the command if this hazard zone has been assigned to this device. The display backlight is activated also to show that the device has received the command. This is useful if you want to test if the device responds to the hazard zone commands.

28.6.6 The menu item 'Terminal Programming'

According to the similarities between the L-Flame and the Galaxis Advanced receivers we also speak of a Terminal programming when operating the L-Flame. Terminal programming means that several firing cues are programmed to a specific output and different durations can be defined in doing so. In principle the L-Flame Flame Head is an Advanced receiver with a single output. Consequently user-defined flame effects like various flame bursts or flame columns can be generated again and again during a show.

TIP

In this section the programming of the Terminal function in the menu of the L-Flame Flame Head is explained. Please note in this context that all these parameters can also be programmed remotely - which is very convenient - by using either the controller PFC Advanced or any PC or notebook computer via the wireless USB modem PFM Advanced.

28.6.6.1 Overview regarding the parameters of the Terminal programming

The following parameters can be programmed at the L-Flame Flame Head for each firing cue (1...999):

Parameter name	Range of values	Resolution
Duration	0.1 ... 25.0 seconds	0.1 seconds
Step Delay	0.00 ... 99.99 seconds	0.01 seconds = 10 ms

The parameter 'Duration' determines how long the fuel valves will be opened. Shorter values for the duration create flame balls, longer values create flame columns.

With the parameter 'Step Delay' time delays are programmed. By doing so the most extreme step sequences can be achieved. The high resolution of only 10 ms enables the user to create extremely fast step chases and dynamic changes in the stepping speed. The functionality is identical with the receiver PFE Advanced 10/100 Outputs and in the user manual of this device the application of the step function is described in detail.

28.6.6.2 The selection menu of the Terminal programming

By activating 'Up' and 'Down' you may choose between the following options:

```
Terminalprogr.:
Keep up & Exit
```

```
Terminalprogr.:
Edit
```

```
Terminalprogr.:
Delete
```

28.6.6.3 The menu item 'Terminal programming: Keep up & Exit'

```
Terminalprogr.:
Keep up & Exit
```

If you activate 'Mode' here you quit the menu of the Terminal function without having changed any parameter. Use this selection also if you want to exit the menu of the terminal function after having made another selection before, for example after having entered a programming.

28.6.6.4 The menu item 'Terminal programming: Edit'

```
Terminalprogr.:
Edit
```

If you activate 'Mode' here you will enter the menu for editing the terminal function.

```
C: 1↕ T: ---s
D: 0.00s
```

'C' stands for 'Cue', which is the firing channel.
'T' is the parameter duration ('T' for lat. tempus).
'D' stands for 'Delay', which is the step delay.

After invoking this edit menu firing cue 1 is pre-selected. The double-headed arrow indicates which parameter can be currently changed with 'Up' and 'Down'. After deletion of the memory no durations are programmed at all. In this case '---' is being displayed for the duration. '0.00' is being displayed as a step delay.

If '---' is being displayed for the duration, this means that for this firing cue no flame will be generated by this device.

Programming example:

- Firing cue 4 should generate a short fireshot with a duration of 0.3 seconds
- With cue 7 a flame column with a duration of 1.9 seconds should appear.
- Cue 17 should trigger a short flame ball with a duration of 0.5 seconds. This flame effect is part of a step sequence and due to that a step delay of 1.47 seconds should be counted down before the effect will be generated.

```
C: 4↕ T: ---s
D: 0.00s
```

As long as the double-headed arrow is being displayed next to the cue number you can select the cue, in this example cue 4, which should be assigned with a flame effect by activating 'Up' and 'Down'.

```
C: 4↕ T: ---s
D: 0.00s
```

With each short activation of 'Mode' the double-headed arrow jumps to the next parameter. You have to activate 'Mode' once for a short time to determine the firing duration.

```
C: 4 T: ---s↕
D: 0.00s
```

Now you can enter the duration for this firing cue by activating 'Up' and 'Down'.

C: 4 T: 0.3s
D: 0.00s

According to the programming example 0.3 seconds have been entered.

C: 5 T: ---s
D: 0.00s

Activate 'Mode' two times for a short period to skip the parameter step delay. Then you will have the opportunity to edit the programming of the next cue. If the double-headed arrow jumps to the cue number again the cue number will be incremented automatically.

C: 7 T: ---s
D: 0.00s

Select cue number 7 by activating 'Up' two times for a short period.

C: 7 T: 1.9s
D: 0.00s

Jump to the parameter duration by activating 'Mode' once for a short period and enter the value 1.9 seconds with 'Up' and 'Down'.

Springen Sie mit einer kurzen Betätigung von "Mode" zum Parameter Ansteuerdauer und stellen Sie mit "Up" und "Down" den Wert 1,9 Sekunden ein. Values greater than 3.0 seconds should not be used. This flame system is not suitable for producing long standing flames. It is possible to set longer times here because nozzles may be available in the future that allow this at lower flame heights.

C: 8 T: ---s
D: 0.00s

Skip the parameter Step delay and get to firing channel 8.

C: 17 T: ---s
D: 0.00s

Select cue number 17 with 'Up' and 'Down'.

C: 17 T: 0.5s
D: 0.00s

The you program, as already described above, an effect duration of 0.5 seconds.

C: 17 T: 0.5s
D: 0.00s

Jump to the next parameter by using 'Mode'. Then enter the desired step delay by using 'Up' and 'Down'.

C: 17 T: 0.5s
D: 1.47s

Here a step delay of 1.47 seconds has been programmed. As soon as you are finished with your entries activate 'Mode' for a longer time to exit the edit menu.

Terminalprogr.:
Keep up & Exit

Right after doing so the device returns to the submenu of the Terminal programming. With another activation of 'Mode' for a short period you will exit this submenu and reach the main menu.

WARNING



Basically, you should try to keep step delays as short as possible. Otherwise, this can cause a hazard, because if the radio link should stop working due to an interference, then the flame effects would continue, even if you cancel the operation on the PFC Advanced controller (switching off the firing mode or switching off hazard zones). A good guideline is that the delay times should not be longer than the human reaction time of about one to two seconds. The use of an E-Stop can also increase safety and allow longer step times.

TIP

By activating the magnetic sensor fields 'Up' and 'Down' for a longer time you can change the current parameter rapidly.

TIP

The parameters flame duration and step delay can also be programmed remotely, which is very convenient, either with the controller PFC Advanced or the Galaxis PYROTEC Composer software in conjunction

with the wireless USB modem 'PFM Advanced'. Furthermore, you can and perform remote data request.

28.6.6.5 The menu item 'Terminal programmierung: Delete'

Terminalprogr.:
Delete

All possibly programmed durations (T) and all step delays (D) in the memory of the L-Flame Flame Head will be deleted with this function.

Are you | Yes
sure? | No

After activating 'Mode' this safety request is being displayed and you can start the deletion process with 'Up'.

The memory has
been deleted!

This message is being displayed after deleting the memory, which only takes a short moment. Subsequently the device returns to the submenu of the Terminal programming.

28.6.7 The menu item 'Scanning Memory...'

This menu item is displayed only very briefly. It serves as information that the process takes a certain time.

Scanning
Memory...

Please wait while the device analyzes the memory content. Immediately afterwards, the device displays the acquired information.

28.6.8 The menu item 'Number of cues programmed'

This menu item is used to display the previously obtained data.

No. of cues
programmed: 74

In this example, the device has determined 74 programmed firing channels, also referred to as cues. This means that 74 of the maximum possible 999 cues have flame duration programming. If you know how many cues must be programmed, you can compare this with the result.

28.6.9 The menu item 'Total flame duration'

This menu item is also used to display the previously acquired data.

Total flame du-
ration: 51.7s

In this example, the device has determined a total flame duration of 51.7 seconds. On the one hand, this information can be used for checking purposes. In addition, this information can also be used to determine the consumption quite accurately.

28.6.10 The menu item 'Delay program. with T=0.0'

This is an error message which is only displayed if cues have delay programming but no firing channel assignment. If this is the case, you will see for example this message in the display:

```
Delay progr.
with T=0.0: 3
```

Here three programmed step delay times have been identified, which have no cue programming. This makes no sense because these flame events cannot be triggered.

If you see this error message, you should call up the terminal programming again. Either delete the faulty entries or program the required firing channels. However, if you ignore this message, the device would also work correctly. It is only an information that indicates programming errors.

28.6.11 The menu item 'Keyboard Firing Mode'

The Keyboard Firing Mode is only available if the control mode 'Radio' has been selected. This gives you the opportunity to control the L-Flame Flame Heads via a DMX desk connected to the PFC Advanced. Please see the notes in the manual of the PFC Advanced under 'DMX Firing Mode'.

For using the Keyboard Firing Mode there is no special programming of the L-Flame Flame Heads necessary. When a keyboard cue is received as 'high', a flame will be generated until the keyboard cue is received as 'low'. If the devices receive only a short 'high', a flame will be generated for 140 ms.

In this menu item you can switch the Keyboard Firing Mode on or off. If you activate the Keyboard Firing Mode, you must also select which keyboard channel the L-Flame Flame Head should react to. Ten channels are transmitted. Of these, the L-Flame Flame Head can evaluate one channel.

With the PFC Advanced, you must set a start channel for DMX reception. For example, DMX channel 25. If you now set the L-Flame Flame Head to keyboard channel 1, then when you press the flash button for DMX channel 25 on the DMX console, the L-Flame Flame Head generates a flame that burns until you release the button again.

The maximum duration limit for the flame duration is also applicable here from L-Flame Flame Head Firmware version 2.24 on.

Note that the Keyboard Firing Mode is an additional function. Conventional programming of the L-Flame Flame Head is still valid. Therefore, make sure to delete the programming if you do not want to use it.

```
Keyboard Firing
Mode: Off
```

You can enable the Keyboard Firing Mode by activating 'Up' or 'Down'.

```
Keyboard Firing
Mode: On CH 1
```

Now set the desired keyboard channel by activating 'Up' or 'Down'. Ten channels are available. To confirm the selection, activate 'Mode'.

If at least one of the ten keyboard channels is received as 'high', the 'Fire' protocol of the PFC Advanced will be sent. The L-Flame Flame Head will show this in the display with 'Fire Keyboard', even if the set keyboard channel is not 'high'.

TIP

In general, a mixed operation between conventional firings and Keyboard firings is possible. Always the command which has been received the latest takes place.

28.7 The menu item 'Flame monitoring'

The device has an optical flame monitoring system.

Flame
monitoring: On

Here the shutoff of the flame effect and of the fuel valves if the flame is not burning is enabled. If no flame is detected for more than a short period of time the valves are closed automatically. The device is terminating the fuel supply for this firing command.

Flame
monitoring: Off

With this setting the results of the flame monitoring system will be ignored.

TIP

With every new firing command another attempt will be made to ignite the flame and in this process the fuel valves will be opened for a short period of time. If no flame can be ignited several times one after another you should disable the L-Flame for the reasons of safety either by using the emergency off input or the hazard zones (Advanced wireless module required for this) to prevent that an unnecessary amount of unburned fuel is set free.

TIP

For the reasons of safety, you should generally enable the flame monitoring system.

WARNING



2.3.2

Ignition failure

The ejected fuel does not ignite.

- Make sure that the required safety distance to persons is maintained.
- Minimize the presence in the danger zone.
- Activate the flame monitoring system.
- Never keep body parts above the combustion chamber at any time.
- Follow all safety instructions and regulations at all times.

28.8 The menu item 'Number of Allowed Misfirings'

This menu item is only displayed if the flame monitoring has been activated in the menu.

When flame monitoring is activated, it is possible to have the unit automatically lock itself out after a certain number of misfires.

No. of Allowed
Misfirings: -◆

Here this function is not in use. The unit will not count the misfires and will take no action in case of misfires. Of course, the flame monitoring will close the valves in case of a misfire if the flame monitoring is enabled.

Each time the flame monitor detects a misfire, the counter is incremented by 1.

No. of Allowed
Misfirings: 5

In this example a limit of five misfires has been set.

Firings Stopped
Misf. Exceeded

If the set number of misfires is reached, the screen on the left is displayed each time the unit is triggered. In this case, no ignition takes place for the remaining operating time of the device. To reset the message, the device must be restarted.

28.9 The menu item 'Max. Flame Duration'

This menu item is only displayed if 'DMX512' has been selected as the input. If you want to use this menu item also in cable (RS485 cable mode of PFC) or wireless mode, please note the instructions in the section 'Activate flame options in cable and wireless mode'.

For special applications or for safety reasons, it may be necessary to be able to limit the flame duration in DMX mode. In this case, the flame goes out after the time preset in the menu. If DMX512 or Keyboard Firing Mode has been selected as the input mode, the dimmer value of the flame channel must be set to 0% in order to trigger a new firing.

Maximum Flame
Duration: ----

With this setting no time limitation will take place.

Maximum Flame
Duration: 1.5s

A limit of 1.5 seconds was programmed here. The setting range is 0.1 to 25.0 seconds. The resolution is 0.1 second.

28.10 The menu item 'Flame Quota'

This menu item is only displayed if 'DMX512' has been selected as the input. If you want to use this menu item also in cable (RS485 cable mode of PFC) or wireless mode, please note the instructions in the section 'Activate flame options in cable and wireless mode'.

In this menu item, you can define a quota that specifies how long the flame may burn in total before it switches off or is prevented from firing again. As soon as the quota has expired, it can be reset at the PFC via range test on channel 777. When the device is switched on again, the quota is reset to the duration set in the menu, i.e. there is no permanent memory storage of a quota that has already started.

Flame Quota:
----s

In this screen view, the flame quota has been deactivated, so firing without time restrictions is possible. You can increase the quota in steps of one second, up to a maximum of 199 seconds. The reason for the high maximum value is that there are applications where such large quotas are useful.

Flame Quota:
12s

Here a flame quota of 12 seconds has been programmed.

Remaining Flame
Quota: 5s

The actual usage of the active quota is regularly shown in the display during operation, and also after each flame generation, this display occurs, with the remaining quota of flame duration in seconds.

Flame Quota
Exceeded!

As soon as the quota is exceeded during normal operation, the adjacent screen appears.

Flame Quota
Reset!

Immediately after resetting the quota on the PFC, this is confirmed with the adjacent screen. The device must be in receiving mode.

28.11 The menu item 'Leakage Monitoring in Head and Hose'

This leakage monitoring by the L-Flame Flame Head is an important safety function which should always be activated. Deactivation is only intended in the event of a malfunction and to allow for continued operation. Do not disable this feature unless instructed to do so by the manufacturer, and then take extra care by watching the system really closely for any leaks. Have a fault in the leakage monitoring system repaired as quickly as possible.

With this leakage monitoring, the Flame Head measures the pressure in the internal system after a flame has been generated and records it. If the pressure drops without any consumption taking place, this is interpreted as a possible leakage. If this is the case, the Flame Head stops any further flame generation and goes to fault. It no longer requests additional fuel from the Pump Station to limit the leakage.

Leakage Monitoring FH+Hose: On

This important monitoring function is switched on here.

Leakage Monitoring FH+Hose: Off

As here, this function should only be switched off in absolute exceptional cases.

<p>WARNING</p>  <p>1.5 2.3.5</p>	<p>Leakage</p> <p>Fuel-carrying lines can leak.</p> <ul style="list-style-type: none"> • Check connections for leaks. • Follow all instructions in the operating manual regarding maintenance. • Do not use the device if leaks are detected. • Follow all safety instructions and regulations at all times.
---	---

28.12 The menu item 'Ignition Coil Monitoring'

The L-Flame Flame Head is capable of measuring the resistance of the ignition coils on the primary side.

If this resistance is within a range programmable by the manufacturer, the unit assumes that the ignition coils are operating properly.

Otherwise, the unit will stop flame generation and go to fault.

It is generally recommended to activate this function. Only if problems occur during signal processing can this function be deactivated to allow further operation.

Have any malfunctions of this function repaired by the manufacturer on occasion.

Ignition Coil Monitoring: On

Here the function is switched on as recommended.

Ignition Coil Monitoring: Off

If the Flame Head is working properly, this function should not be turned off as it is here.

28.13 The menu item '45° Tilt Switch'

The tilt sensor function by means of a tilt switch is only available in the first production batch of the devices. Because the sensors required for this are no longer manufactured, this function is no longer offered in all subsequent batches. Instead, we recommend using the new and much more versatile pan and tilt angle measurement.

In this menu item you can determine if the flame effect should be terminated or if the fuel valves should remain closed if the L-Flame Flame Head is tilted by more than 45°.

45° Tilt Switch:
On

The shutoff of the flame effect and the inhibition of the fuel valves if the tilt angle is too is enabled.

45° Tilt Switch:
Off

The status of the tilt switch will be ignored. Use this selection only if you want to operate the L-Flame Flame Head with a tilt angle of more than 30°.

TIP

The tilt switch is a mechanical component. Strong vibrations or accelerations on the vertical axis may cause the tilt switch to respond even though that the device is standing upright. In these exceptional cases it can be meaningful to disable the tilt switch.

28.14 The menu item tilt sensor selection 'S1, S2 or S3' and introduction into the tilt measurement by utilizing acceleration sensors

The L-Flame Flame Head has a special tilt sensor system, which is not only able to detect the exceeding of the 45° angle, but also with an angle freely programmable by the user within wide limits and a tolerance in degrees also freely programmable by the user.

This inclination sensor technology works with so-called acceleration sensors. The acceleration due to gravity, i.e. the weight force, is measured. Additional accelerations, as they occur during movements due to acceleration (positive acceleration) and deceleration (negative acceleration) are also recorded and are regarded as disturbance variables. I.e. these movements are undesirable and must be avoided if you want to use this tilt sensor technology. Vibrations also count as undesirable disturbance variables, since these also superimpose the weight force.

This technology is also used in smartphones, e.g. to measure the orientation of the device and to show an image correctly rotated on the display. An acceleration sensor is also evaluated by means of an algorithm in a step counter in a smartphone or smartwatch.

The tilt sensor in the L-Flame Flame Head detects all three axes: X, Y and Z. The Z axis is basically the vertical. X and Y represent, in simplified terms, pan and tilt.

The acceleration is measured in g.

1 g corresponds to the acceleration due to gravity of 9.81 m/s².

If the device is vertical, then +1 g is measured on the Z axis and 0 g on the X and Y axes.

If the device is tilted slightly, the value on the Z-axis decreases and the values on the X- and/or Y-axis increase above 0 g or decrease below 0 g into the negative, depending on the direction in which the device is tilted.

The two ratios between the Z and X axes and the Z and Y axes allow the tilt angles in the pan and tilt directions to be calculated using the arc tangent function.

The result of these calculations is a pan angle and a tilt angle.

The device will only ever display these angles, because the g-values are not very informative for the user.

The value range for both angles is -180° to $+180^{\circ}$.

If both angles are 0° , the device is absolutely vertical.

Attention! Due to mathematical laws, this tilt sensor is not suitable for angles close to $+90^{\circ}$ or -90° . Strong angular deflections can occur here and we recommend switching off the tilt sensor system if the device is to be used in this angle range.

Attention! The angle range between -175° and $+175^{\circ}$ should also be avoided due to the sign change and the tilt sensor system should not be used here.

With the inclination sensors in the L-Flame Flame Head, it is completely normal that measurement deviations in the range of a few degrees occur, because sensors are used which are not highly precise. High precision sensors cost a lot and would drastically increase the purchase price of the L-Flame Flame Head.

Nevertheless, in order to measure as accurately as possible, the tilt sensor system is calibrated by the manufacturer before delivery. Should deviations occur due to aging, then this calibration can also be repeated.

Because the L-Flame Flame Head can be mounted in different ways, not only one 3-axis tilt sensor but three different 3-axis tilt sensors were built in.

These three sensors differ in their arrangement with respect to their horizontal X and Y axes by being rotated relative to each other.

This rotated arrangement results in a different orientation of the pan and tilt information with respect to the housing.

Sensor 1 is arranged in such a way that the pan angle goes virtually across the LCD housing. The tilt angle is of course offset by 90° for this purpose. Sensor 1 is used when you look at the LCD from the front when mounting or using the device. If you now tilt the device to the left, a negative tilt angle is the result. Tilting it to the right creates a positive tilt angle. Tilting towards the back of the LCD will result in a positive pan angle, while tilting towards the front of the LCD will result in a negative pan angle.

Sensor 2 is intended for when the device is mounted using the guiding slots to the left of the LCD housing. Here, the same tilt and pan angles are created as explained above, except that these guiding slots and the opposite guide grooves are the reference point.

Sensor 3 is to be used when the device is mounted with the guiding slots to the right of the LCD housing. In this case, this guide groove is then the reference point for the pan and tilt information.

TIP

Starting from a certain production date, a legend has been attached to the Flame Heads on the top side by means of laser engraving, which illustrates exactly this sensor assignment and the pan and tilt directions. If your device is not equipped with this, we can send you adhesive stickers for subsequent attachment, if desired.

In this menu item, the first thing to do is to select the desired sensor. You will see the following display in the LCD, for example:

```
S1♦: Pan:  -001°
      Tilt: +002°
```

Select the required sensor with 'Up' and 'Down'. The device also shows you the calculated pan and tilt angles in degrees here. The displayed values should not change more than $\pm 1^{\circ}$. Otherwise you have to stop the unwanted movements or vibrations. Confirm your selection with "Mode". This will also take you to the next menu item.

28.15 The menu item 'Store Pan/Tilt Angles'

Here you can now specify whether the angles currently measured (not visible) should be saved and used for the tilt sensor system and any shutdowns due to out-of-tolerance conditions:

Store Pan/Tilt
Angles? On

Here you save the angles measured in the background. The relevant measurement takes place at the exact moment you activate 'Mode' and exit the menu item. At the same time, you activate the angle monitoring by means of acceleration sensors with this setting.

Store Pan/Tilt
Angles? Off

If you make this selection and confirm it with 'Mode', the tilt sensor measurement by acceleration sensors is deactivated.

28.16 The menu item 'Pan/Tilt Sensor Tolerance'

This menu item only appears if you have previously activated the tilt sensor system using acceleration sensors.

You must now specify the allowed tolerance for the maximum permitted deviation from the stored angles.

You will see e.g. the following display in the LCD:

Pan/Tilt Sensor
Tolerance: $\pm 10^\circ$ \blacktriangledown

Here the tolerance would be $\pm 10^\circ$. The lowest possible setting is $\pm 3^\circ$. The largest possible tolerance is $\pm 30^\circ$.

TIP

If this menu item is active, the current angles are measured continuously and checked with the set tolerance. If the tolerance is exceeded, this is indicated by the red 'Fault' LED. At the same time, you will hear an acoustic signal in this case. This allows you to determine whether your settings are suitable. Excessive movements or vibrations would also cause a tolerance exceedance to be displayed.

TIP

This setting applies equally to pan and tilt. A tolerance is exceeded as soon as the pan or tilt angle is out of tolerance.

TIP

The set tolerance should not be too narrow but also not too wide. Values between 5° and 10° have proven to be good. Ultimately, you must decide which tolerance is suitable according to your application.

WARNING



Avoiding 90° and 180° in angle measurements

For mathematical reasons, angle measurement using accelerometer technology is not suitable for angles around 90° . In addition, the transition between $+180^\circ$ and -180° is also not detected correctly.

- The tilt sensor technology cannot be used if 85° to 95° degrees are reached by the stored angles plus tolerance.
- The transition between $+180^\circ$ and -180° must also be avoided.
- In these cases, switch off the tilt sensor system and monitor the tilt using other methods.

28.17 The menu item 'Acoustic Signals'

This menu item switches the acoustic signals of the device on or off. Beep tones etc. may be disturbing on theatre stages and in this case, it is meaningful to disable the sounds. Please note that there will be no acoustic signals at all if the sounds are turned off, even no warning signal is given if there is any kind of warning message.

Acoustic
Signals: On

In this example the acoustic signals are enabled.

28.18 The menu item 'LCD Backlight'

This text for example is being displayed:

LCD Backlight:
auto & dimmed

The display backlight is turned on automatically as soon as the menu is called up or messages are being displayed. The display is illuminated slightly (dimmed) in all other cases. That enables you to read the display content in darkness without any further action required. The power consumption for this slight permanent illumination is negligible.

LCD Backlight:
auto & off

If you choose this setting the display backlight is completely turned off as soon as the device is not in the menu or if there is no message. This is preferable in some applications where the slight illumination of the display could be disturbing.

LCD Backlight:
always off

With this setting the display backlight is off all the time.

28.19 The menu item 'Warning LED'

In this menu item the following options can be selected:

Warning LED (!):
On

The warning LED is switched on.

Warning LED (!):
Off

No warning signal will occur.

28.20 The menu item 'Inner Temperature'

The temperature inside of the device is displayed in this menu item as a user information.

Inner Temp.:
23°C

The temperature is allowed to vary in the range from -20 to +65°C. The LCD is becoming slow in extremely cold environments. This effect is completely normal and does not impair the function.

28.21 The menu item 'Relative Humidity inside'

The relative humidity inside the housing is monitored by the device. Within the tight enclosure water condensation is prevented by a drying agent which is drying the air all the time. For more information please refer to the section 'Drying agent in the L-Flame Flame Head'.

Rel. Humidity
inside: 21%

Here, the relative humidity in the device is okay. A value of less than or equal to 30% rH is considered good. If it is higher than 30%, the desiccant should be renewed. In this case, the device informs you of this at every startup.

If the desiccant does not last long, this is an indication of a leak in the housing. If you suspect leakage, you should have the housing checked for leaks immediately.

29 Operation on 5V mains adaptor

For example, in order to not always have to rely on the power supply from the Pump Station when programming the Flame Heads, the option of operating the Flame Heads with a commercially available 5V USB power supply was created.

These power supplies with a suitable cable are available on request.

When starting the unit in this operating mode, you will see the following display in the LCD:

Operation on 5V
mains adaptor

In this case, you can access the menus and also communicate by radio. When flame effects are triggered, neither ignition sparks are generated nor magnetic valves are opened, because there is no 12V DC power supply.

30 Enabling flame options in cable or wireless mode

If you would like to use the flame time limitation or the flame quota also in RS485 cable and wireless mode, this function must be enabled by entering a token.

NOTICE

An active flame duration limitation or a programmed flame quota have priority over the programmed firing durations in the Terminal memory. The flame duration limitation leads to the shutdown of the flame generation when the programmed, maximum flame duration is reached, even if the programmed duration for the firing cue should be longer.

An expired flame quota also leads to immediate shutdown of the flame.

Switch on the L-Flame Flame Head while actuating the sensor field 'Mode' until you see this message in the display:

Enab. Flame | Yes
Options? | No

With 'Up' and 'Down' you can choose between 'Yes' and 'No'. To enable the flame options, you must confirm with 'Yes'.

The following text is then displayed as a ticker:

Call the Galaxis office and tell the token. You will
receive the activation code. Continue with Mode.

If you now activate 'Mode' a random eight-digit sequence of numbers will be generated and displayed, the so-called token. Tell us this token on the phone and will give you the corresponding activation code.

TIP

You may speed up the ticker by activating the 'Mode' sensor field and keeping it activated.

The sequence is as follows:

Token:
53582820

Example of a token being displayed. This screen is being displayed sufficiently long so that you can tell us the token on the phone.

Code?
◆

Then you see this request to enter the activation code which you will receive from Galaxis on the phone. With 'Up' and 'Down' you can change the digits. If you see the correct number being displayed activate 'Mode' to proceed. A '0' can be entered the easiest by activating 'Mode' without activating 'Up' or 'Down' before.

Code? OK
44232502◆

The activation code, which has also eight digits, has been accepted and the flame options have been unlocked.

Code? X
54232502◆

A wrong activation code has been entered and the code was not accepted. Switch off the L-Flame Flame Head and repeat the procedure.

31 Receiving mode or respectively ready to fire mode of the Flame Head

Right after switching on and after the safety timer has elapsed the device enters the receiving or respectively the ready to fire mode. Flame effects and bi-directional remote access functions are only possible in this operation mode. If wireless communications is being used we are speaking of receiving mode. Otherwise it is called ready to fire mode. Which information is being displayed in this mode is depending on the selected control method.

In the following chapter we will describe which messages are being displayed one after another. In general, first the selected control method is being displayed, followed by additional screens regarding the operation status and settings.

31.1 Displayed information during receiving mode or respectively ready to fire mode, that appears in all operation modes

31.1.1 Information which control method has been selected

Depending on the selected control variant one of the following screens is being displayed:

Input: Wireless
(PFC, PFS, PFM)

Input: Cable
(RS485 of PFC)

Input: DMX512
F:003_, S:012X

The programmed flame channel and safety channel is being displayed if DMX512 has been chosen as an input ('F' = Flame channel, 'S' = Safety channel).

In addition, the status of the safety channel or respectively of the DMX reception is being displayed. 'x' means that either no signal is being received or that the value of the safety channel is not within the previously configured range (= generation of flame effects is not enabled).

'✓' after the safety channel indicated that a DMX signal is being received and that a value within the previously configured range is being received for the safety channel (= device armed).

Input: DMX512
F:003♠, S:012✓

This example shows the display content if the device is armed by the safety channel (noticeable by the '✓' after the safety channel) and if the flame channel has activated a flame effect (flame symbol next to the flame channel).

31.1.2 Tilt switch on/off and its status

Tilt Switch: On
Status: OK

In general, it is being displayed if the tilt switch has been enabled or not and the status of the tilt switch. The tilt switch is enabled in this example, i.e. the flame effect will be terminated if already in progress or flame effects will be disabled if the device is tilted by more than 45°. Status OK means that the L-Flame Flame Head is not tilted by more than 45° and the generation of flame effects is enabled.

Tilt Switch: On
Status: >45°

Here the device is tilted by more than 45° and flame effects will be terminated if this condition is detected during a flame effect and the fuel valves will remain closed if the tilt angle is exceeded in the moment of triggering an effect.

Tilt Switch: Off
Status: >45°

The tilt switch has been turned off in the menu. The L-Flame Flame Head will ignore a tilt angle of more than 45° and flames will be generated, no matter how much the device is being tilted.

31.1.3 Flame Monitoring on/off

Flame monitoring: On

Here the flame monitoring system has been deactivated in the menu. The device is measuring the radiation of the flame immediately after the beginning of the ignition phase to determine if the flame is really burning and if it has been completely ignited. If the flame is not burning the valves will be closed.

Flame monitoring: Off

In this example the flame monitoring has been disabled in the menu of the device.

31.2 Display of special information and behavior of the device in the receiving mode or respectively ready to fire mode if 'Wireless (PFC, PFS or PFM)' or 'Cable (RS485 or PFC)' has been selected as control method

After the selected control method, the status of the tilt switch and the flame monitoring system will be displayed. Right after that the following screens will be visible:

31.2.1 Status informationen regarding firing mode and hazard zone

Firing Mode: Off
Hazard Zone: G✓

The status of the firing mode is being displayed (on or off). Please note in this context that the device is assuming that the firing mode is disarmed at the controller when being switched on. If the L-Flame Flame Head is powered after the firing mode has been armed 'off' will be displayed nevertheless. Furthermore, this wrong usage leads to the detection of a radio interference because the L-Flame Flame Head interprets the signal of the controller as an interference.

In addition, the hazard zone the device has been assigned to plus if this zone is active or not is being displayed ('✓' = active, 'x' = inactive). The hazard zone is active by default after powering up the device and must be deactivated by a command from the controller if necessary.

If the status of one of these parameters is changing the device immediately jumps to this screen and in addition the display backlight is switched on, if it has been enabled in the menu.

TIP	Every time the firing mode is turned on or off the controller transmits this information to the receiver. If the status of the firing mode is being changed the L-Flame Flame Head can only display the current status of the firing mode correctly if they are in the receiving mode and within radio coverage.
------------	--

TIP	If the firing mode is being switched off all possibly opened electromagnetic fuel valves are closed (command 'Firing mode off'). In addition, all stepping sequences that are currently in progress are terminated, provided that the L-Flame Flame Heads are within radio range and that this information is being received.
------------	---

31.2.2 Display of the device ID number

Dev. ID No. for
bidir. Comm.: 15

Then the device ID number for bi-directional communication which has been assigned to this L-Flame Flame Head is being displayed.

31.2.3 Display of messages

The following messages are possible if the Advanced wireless communication module is being used. If enabled in the menu the display backlight is switched on, too, so that it becomes apparent which device is displaying a message.

Transmitting
data...

A remote access is currently in progress. The device is transmitting data to the controller or the wireless USB modem.

Writing
data...

A remote access is currently in progress and data is written to the memory of the L-Flame Flame Head.

Remaining Range:
75%

A radio range test is currently in progress and the result is being displayed (no bi-directional remote access but a range test as it is can be conducted with the PFS Profi or PFS Pocket and as it has been also implemented in the PFC Advanced to provide downward compatibility to devices of the Profi series).

Fire CH: 999

This is being displayed when firing commands are being received. If a flame effect has been programmed for the firing cue the yellow 'Flame' LED goes on in addition or it starts to flash if a step sequence is in progress or started.

Fire CH: 999
No system press.

If the pressure control is off, you will see a message to this regard in the second line of the LCD. In this case, no flame can be generated and the fuel valves remain closed.

RF Channel: 69
= 434.775 MHz

The L-Flame Flame Head received the command to change the radio frequency. The new radio channel and the frequency is being displayed.

31.2.4 Programming of the System ID

The L-Flame Flame Head can be taught to different systems ID, just as it is possible with the Advanced receivers. This procedure is called 'Teach-In' and is used if systems are split into several ones or if devices are lent or rented out to other customers. After the return of the devices they can be e.g. taught to the original System ID again.

To teach-in a System ID 'Up' must be activated while the device is in receiving mode and then the command for the teach-in must be sent. Immediately after that the following confirmation message is being displayed on the LCD of the L-Flame Flame Head:

Teach-In successful

The device will automatically return to the receiving mode after this message.

31.2.5 Setting and loading default settings

If required, you can reset all settings to default values with a single command after previous configuration. This is useful, for example, if the device was rented out and is to be reset to defined default settings after being taken back. To determine which values are to be defined as default settings, you need two magnetic pins. Please proceed as follows:

With the device switched off, activate 'Mode' and 'Down' at the same time.

Specify	Yes
Defaults?	No

Confirm the prompt by activating 'Up'.

Navigate through the menu and define your desired default settings. After exiting the menu, the values are saved in the memory and can be loaded into the main memory as described in the next step.

If you then want to reset the device to default settings, proceed as follows:

With the device switched off, activate 'Mode' and 'Up' at the same time.

Set to	Yes
Defaults?	No

Confirm the prompt by activating 'Up'.

Device has been set to defaults

As soon as the device has been reset to default settings, this is indicated on the display with a corresponding message.

Please note that resetting also deletes all programmed durations (T) and all step delays (D) in the memory of the L-Flame Flame Head.

31.2.6 The monitoring function Radio Interference

The L-Flame Flame Heads are monitoring their frequency permanently. An interference is present if an external carrier with a signal strength of more than 30% in respect to 100% maximum signal strength of the system is present for more than 45 seconds.

Radio Interference!

This message is appearing if a radio interference has been detected. If the display backlight has been activated the display will be illuminated periodically, too. In this case it is advisable to check if the L-Flame Flame Head has been installed close to a strong source of interference. Therefore, enter the menu item 'Interfering Signal' and check if there is a higher value all the time.

By stepping through the menu with the magnetic pen the warning 'Radio Interference' will be cleared. The device is always ready for use even if you do not clear this warning message.

TIP	If you switch on a L-Flame Flame Head while the transmitter is in the firing mode the L-Flame Flame Head will display the warning message 'Radio Interference' soon. The PFS Profi, PFS Pocket and the PFC Advanced are transmitting continuously (i.e. they are active carriers) if they are in the firing mode. If you change from normal mode to firing mode the controllers are telling the receivers that a continuous and intended transmission will follow. If a L-Flame Flame Head has been switched on after this or was in the menu while this signal has been sent it will interpret the signal of the own transmitter as an interfering signal.
TIP	You can select another frequency in the menu of the device if the used radio channel is busy or if there is an interference. Of course, you have to select the same frequency also at the controller and all other receivers if additional devices are in use (only possible with Advanced series).
TIP	The frequency (i.e. radio channel) can also be changed remotely with the controller PFC Advanced or the wireless USB modem PFM Advanced.
TIP	Using the controller PFC Advanced the warning 'Radio Interference' and the level of interference can even be checked remotely.

32 Switching off the system

You should only turn off the Pump Station and connected Flame Heads when all units are in receive or normal mode.

You should also not switch it off while a remote programming or a remote check is performed by the Advanced wireless module.

Actuate the main switch to switch off the device.

<p>CAUTION</p>  <p>2.4.3 2.5.1</p>	<p>Strong heating of the device during operation</p> <p>During operation, the following parts of the device can heat up considerably:</p> <ul style="list-style-type: none"> • the casing, in particular the parts forming the combustion chamber • the ignition electrodes <p>Do not touch these parts until they have cooled down sufficiently and the unit is switched off.</p>
--	---

Alternatively, you can also power down the unit by using the emergency off input, i.e. by opening the electrical contact that is connected to this input. In principle the main switch and the emergency off switch are wired in series. Please note when powering down the device with the emergency off input that still there is a small power consumption. Due to that you should also switch off the device with the main switch if the device is not used for a longer time.

The usage of the emergency off input is very recommendable to power down the device with sufficient safety distance and then turn the main switch to the 'off' position. Especially when using DMX512 we recommend this procedure because this control signal contains no safety measures.

33 Command 'Firing mode off'

If you operate the Advanced wireless module you can send the command 'Firing mode off'. This command is always being sent when the firing mode is disabled. If this command is being received opened electromagnetic fuel valves are closed, the electrical ignition is switched off and step sequences - if in progress - are terminated, provided that the L-Flame Flame Head is within radio range and the command is being received.

34 Trouble shooting if error message 'Fail Safe triggered' or other error messages are being displayed:

Firmware L-Flame Pump Station V2.25 or newer and L-Flame Flame Head V2.20 or newer. Older versions may differ in detail with regard to the displays. In the first versions, only error codes were displayed.

If none of these solutions works for you, we will be happy to help you by phone or e-mail.

E-Mail: info@galaxis-showtechnik.de
Phone: +49 8671 73411

34.1 Pump Station

If a fault occurs in the Pump Station, the system is always put into a safe state, called Fail Safe. This ensures that no damage can occur to the device and that there is as little danger as possible from the devices.

When the Pump Station goes into a safe state, the following happens:

- The pressure accumulators of the Flame Heads are drained and depressurized, provided the fuel tank is not overfilled.
- The internal system of the Pump Station is depressurized, provided the fuel tank is not overfilled.
- The device displays 'Fail Safe triggered' and a more detailed and very important error message.
- The device must be switched off and on again to end the safe state.
- If the error occurs again, the device enters Fail Safe again.

34.1.1 Timeout Pump Duration (formerly error code 1):

This is being displayed one after another:

Fail Safe
triggered!

Timeout Pump
Duration

Battery fully
charged?

See user manual
how to proceed!

↑ = Pump out
Tank

The programmed pressure cannot be reached within a certain time. The pumps have been switched off to prevent damage to the battery and the pumps.

Please check:

- Is there enough fuel in the tank?
- Is the battery fully charged? The power consumption of the pumps is very high!
- Charge the Pump Station battery whenever possible.
- A full battery charge takes at least approx. 14 hours. Charge the battery fully before every show. One battery charge is sufficient to pressurize approx. five times the tank volume and pump it to the heads.

If the battery is too empty, you can also hear this in the pump noise. The pumps then struggle to reach the pressure and run at a lower speed.

34.1.2 Internal pressure loss! Leakage? (formerly error code 2):

This is being displayed one after another:

Fail Safe
triggered!

Int. pressure
loss! Leakage?

See user manual
how to proceed!

↑ = Pump out
Tank

There was an implausible pressure loss in the Pump Station.

You need to do:

- Check for damaged hoses and connections.
- Check whether there are any leaks.
- If in doubt, stop operating the devices.
- You can switch off the leakage monitoring, but this is not recommended for safety reasons.
- If you switch off the leakage monitoring and the pressure cannot be kept stable, if there is no consumption, there is probably a defect in the form of a leak. Send the device to the manufacturer for repair if the problem cannot be rectified.

Particularly with relatively new device, it has happened that a production-related metal chip has come loose and caused a pressure loss at a non-return valve, for example. Filters prevent the entry of foreign objects from outside.

34.1.3 Tank overflow, lower sensor (formerly error code 3):

This is being displayed one after another:

Fail Safe
triggered!

Tank overflow,
upper sensor

See user manual
how to proceed!

↑ = Pump out
Tank

Please check:

- Is the tank too full?
- Has the device been moved or tilted so that the fuel in the tank sloshed to the side? This can trigger the overflow sensor.

Make sure that the Pump Station is not moved or tilted and that it is level.

Make sure that there is not too much fuel in the tank.

Do not fill the tank if the system is under pressure. This can result in the tank may become too full when the pressure is discharged.

In this state, it is possible to pump out the tank. Please follow the user manual in this case.

34.1.4 Tank overflow, upper sensor (formerly error code 4):

This is being displayed one after another:

Fail Safe
triggered!

Tank overflow,
upper sensor

See user manual
how to proceed!

↑ = Pump out
Tank

Please check:

- Is the tank too full?
- Has the device been moved or tilted so that the fuel in the tank sloshed to the side? This can trigger the overflow sensor.

Make sure that the Pump Station is not moved or tilted and that it is level.

Make sure that there is not too much fuel in the tank.

Do not fill the tank if the system is under pressure. This can result in the tank may become too full when the pressure is discharged.

In this state, it is possible to pump out the tank. Please follow the user manual in this case.

34.1.5 Fuel in drain tray detected (formerly error code 5):

This is being displayed one after another:

Fail Safe
triggered!

Fuel in drain
tray detected!

See user manual
how to proceed!

↑ = Pump out
Tank

You need to do:

- Stop using the device.
- Check for leaks.
- To drain the fuel in the drip tray, you can unscrew the two front housing feet. The threaded holes serve as a drain opening.
- Send the device to the manufacturer for repair.

34.1.6 Emergency Off contact open (formerly error code 4):

This is being displayed one after another:

Fail Safe
triggered!

Emergency Off
contact open!

See user manual
how to proceed!

The device has detected an open contact at the emergency stop input. For safety reasons the safe state has been triggered. The flame heads are no longer supplied with power in order to ensure safety.

You need to do:

- Connect your emergency stop switch here. Unlock this when safe operation is guaranteed and only then switch the device on.
- For non-critical operating phases, you can plug in the jumper plug instead of the emergency stop switch.

34.2 Flame Head

34.2.1 Pressure loss in hose and head:

This is being displayed one after another:

Fail Safe Cond.
Error code 1

Pressure loss in
hose and head!

Leakage?

The Flame Heads monitor the hose to which they are connected and their internal system for implausible pressure losses. Such an event has been detected.

This needs to be done:

- Check for damaged hoses and connections.
- Inspect for leaks.
- If in doubt, stop operating the devices.
- You can switch off the leakage monitoring in the Flame Heads, but this is not recommended for safety reasons.
- If you switch off the leakage monitoring and the pressure cannot be kept stable, if there is no consumption, there is probably a defect in the sense of a leakage. Send the device to the manufacturer for repair if the problem cannot be eliminated.

34.2.2 Ignition terminated, minimum pressure reached

Ign. terminated!
Min. Pressure!

The Flame Heads monitor the pressure before and during flame generation. If this pressure is too low, a lot of fallout occurs. To prevent this, the Flame Head purposefully switches off the flame generation.

Please check:

- Is a sufficiently high pressure set at the pump station? If the pressure is too low, this leads to fallout and shutdowns.
- If you see this error message, it is usually because you have overloaded the system by triggering it too long and too often. The pumps were then no longer able to pressurize enough fuel to the required level and deliver it to the flame heads.
- Also check whether the hoses and connections are in order.
- Inspect whether there are any leaks.
- If in doubt, you may no longer use the head and the hose.

34.2.3 Message 'No system pressure'

```
Fire CH:      XYZ
No system press.
```

No flame was generated because there is no system pressure.

If you see this message, please check the following:

- Is the Pump Station tank sufficiently full?
- Is the pressure control at the Pump Station switched on?
- Does the Pump Station display a plausible value for the actual pressure?
- Are the hose and the data line connected correctly?

34.2.4 Message 'Ignition terminated!, Ignition Coil Failure'

```
Ign. terminated!
Ign. Coil Fail.
```

The device measures the energy consumption of the ignition coils. If this is very low and therefore implausible, an error message is displayed if monitoring is switched on.

This function is a new feature. Previously, the user had the option of switching the function on and off. As there were some unjustified deactivations, it was decided not to release the function in newer firmware for the time being until we have more data on meaningful deactivation criteria. If you find a menu item for deactivation in the menu, you can switch off this monitoring function at any time.

34.2.5 Message 'Ignition terminated!, No flame detected'

```
Ign. terminated!
No flame detect.
```

This message is displayed if the flame monitoring is switched on and the optical flame monitoring in the flame head has not detected a flame.

Please check:

- Does the flame burn well and intensely when triggered?
- Is there sufficient system pressure?
- Is the measuring window (the small glass window in the LCD housing) clean, dry and free of grease?

In heavy rain, you may have to switch off the flame sensor system to enable operation. In this case, be particularly careful and monitor the devices very carefully. You should switch the flame sensor back on when conditions permit.

If problems persist, please contact us for repair or troubleshooting.

34.2.6 Message 'Ignition terminated!, Device tilted!'

```
Ign. terminated!
Device tilted!
```

The tilt angle was out of tolerance. Please follow the instructions in the operating manual. Set the desired tilt angle and the tolerance correctly.

Strong shocks or vibrations can cause the inclination to be measured incorrectly. In such cases, you must switch off the tilt sensor. In this case, you must monitor the devices very closely to ensure that they are correctly mounted or correctly positioned. However, you should switch the tilt sensor back on again if circumstances permit.

A very narrow tolerance can easily lead to shutdowns. Therefore, check whether you can increase the tolerance slightly in your application.

34.2.7 Message 'Fire Channel: XYZ, No system pressure'

```
Fire CH:      XYZ
No system press.
```

A flame cannot and must not be generated because there is insufficient system pressure. The flame head is therefore blocking flame generation.

Please check:

- Is the pump station tank sufficiently full?
- Is the pressure control on the pump station switched on?
- Does the pump station display a plausible value for the actual pressure?
- Are the hose and the data line connected correctly?

35 Radio range

If the standard antenna is used under good conditions the range is 800 m and can be increased up to 2.000 m by using the antenna Superscan 70 or Superscan 71.

Higher radio range is available on request.

It is a general rule that the higher the antenna is positioned the better the reception will be. Please do not hesitate to ask our personnel for more information about the various possibilities of range improvement.

TIP

An antenna extension cable should be used for the Superscan 70 or Superscan 71 in order to mount the antenna separated to ensure that the generated flame cannot damage the antenna.

TIP

Do not use the high gain antennas Superscan 70 and Superscan 71 together with the remote access functions because in this mode the device is also transmitting data and the radio approval would be voided.

36 Radio range test

The remote access functions of the controller PFC Advanced make very convenient radio range tests possible because the signal strength of both devices (signal back and forth) are displayed at the controller.

If you want to read the test result at the L-Flame Flame Head or if you work with the transmitter PFS Profi or PFS Pocket the radio range test can also be done the conventional way.

After starting the test procedure, the L-Flame Flame Head will for example display the following text:

Remaining Range:
75%

This result means that the distance to the transmitter can be approximately doubled until the signal will be too low. In general, you should try to achieve at least a signal level of 30%.

37 Remote access

If the device has been accessed remotely via the wireless link or the serial data cables one of the following text messages will be displayed depending whether data is being read from the device or data is being written to the memory of the device:

Transmitting
data...

The device is transmitting while the controller or the wireless USB modem is receiving data.

Writing
data...

The controller or the wireless USB modem is transmitting data which is written to the memory of the L-Flame Flame Head.

If the radio channel is being changed by a remote command the new radio channel and the frequency in MHz is being displayed:

RF Channel: 69
= 434.775 MHz

38 Operating time

After switching on the Pump Station, energy is continuously drawn from the internal battery.

Depending on how many Flame Heads are connected, the operating times in normal mode vary:

Pump Station with one Flame Head: approx. 120 h
Pump Station with two Flame Heads: approx. 80 h
Pump Station with three Flame Heads: approx. 60 h

The pumping operation puts much more strain on the battery and drains it much faster.

As a rule of thumb, a full battery, which also has the nominal capacity, i.e. is as good as new, can be used to pressurize the full tank volume of the Pump Station about five times and consume it with the Flame Heads before a recharge is required.

Basically, the Pump Station has a much higher power consumption than, for example, the G-Flame, because the electrically operated pumps require a lot of energy. It is therefore recommended to charge the battery sufficiently long before each use. If the battery is heavily discharged, this will take about 20 hours. It is a common mistake not to charge the battery sufficiently.

39 Performing a field strength calibration of the L-Flame Flame Head

This only applies if the Advanced radio module is in use.

Your device is calibrated at the factory before it is delivered. However, it may be necessary for you to calibrate the field strength measurement yourself:

1. You perform a firmware update yourself. In doing so, a field strength calibration is only necessary if one has never taken place before.
2. The device is operated under extreme climatic conditions (very high or very low ambient temperatures), which may require temperature compensation in the form of field strength calibration.

```
Cal. Field | Yes
Strength?  | No
```

If you perform a firmware update and no calibration has taken place before, the device prompts you for calibration during startup. You can skip the prompt, but in this case, inaccurate or erroneous field strength readings may occur. Calibration is therefore strongly recommended.

To start a field strength calibration independently of an update, activate 'Mode' while switching on the L-Flame Flame Head. Remove the magnetic pen again and activate 'Mode' twice until you see the screen content shown above.

To perform the calibration, you need a PFC Advanced, hereinafter referred to as the 'auxiliary device'. Please follow the steps below:

1. Make sure that you are in an environment with the lowest possible radio interference. There should be as few electronic devices or electrical installations in the vicinity as possible.
2. The L-Flame Flame Head must be set to the same radio channel and the same System ID as the auxiliary device. The antenna on the L-Flame Flame Head must first be unplugged.
3. Switch on the auxiliary device.

```
Antenna    | OK
removed?   |
```

If you have previously selected 'Yes', then you will see this display. The device asks you to disconnect the antenna. Check this and then actuate 'Up', 'Down' or 'Mode'.

```
Please
wait...    [031]
```

The device performs a measurement and displays a measurement result. This is only of interest for support in the context of troubleshooting.

```
Antenna    | OK
installed   |
```

The device prompts you to plug the antenna back in. When this is done, you can proceed to the next step by selecting 'Up', 'Down' or 'Mode'.

```
Arm Firing Mode
at PFC     [135]
```

Activate the firing mode on the PFC. The device shows you a measurement result again, which is only of interest in case of support.

```
Calibration
successful!
```

Once the calibration has been successfully performed, you will see the adjacent screen. You can now switch off the auxiliary device. The calibration values have now been permanently stored in the memory.

```
Calibration
Failed! [E1]
```

During calibration, errors may occur in the event of problems with the hardware, incorrect operation or due to external influences, so that the calibration is aborted. In any case, an error message with the corresponding error code will be displayed. In this case, please contact us in order to carry out an error analysis and tell us the displayed error code.

40 Installation of accessories

<p>DANGER</p>  <p>2.3.7</p>	<p>Use of non-original accessories or operation without specified components</p> <p>The safe operation of the device cannot be guaranteed, if non-original accessories and components are used. All specified parts must be used to operate the device (e.g. pressure reducer).</p> <ul style="list-style-type: none"> • Use only components and accessories approved by the manufacturer. • Use all components specified by the manufacturer.
---	---

41 De-Installation of the radio module

A de-installation of the radio module is currently not foreseen for regulatory reasons. The Flame Heads are generally equipped with a radio module, with one variant for operation in Europe and another variant for operation in the USA and Canada.

42 Configuration of the Advanced wireless module

Due to the fact that the end user should not change the radio module no information is given here. In case of any questions please contact support.

43 Usage in rain

The L-Flame Pump Station is designed to be protected from rain, drizzle, moisture and humidity. It is designed to be installed on, next to and behind stages where this is ensured.

The L-Flame Flame Head can also be used in rainy conditions. When the high voltage electrical ignition is turned on, a very hot arc is produced immediately and fuel ignition usually works without problems even in heavy rain. The optical flame monitoring window can be treated with water repellent spray to make raindrops drip off. If water keeps getting on the measuring window, the flame monitoring system may have to be shut down to allow operation.

44 Drying agent in the L-Flame Flame Head

44.1 General information

The air volume inside of the device is hermetically sealed. To prevent water condensing if the device is used in cold environment a pack of desiccant has been put in during assembly. The desiccant is drying the air constantly. The dried air completely prevents corrosion in the long run and a very high lifetime expectancy is achieved.

The device monitors electronically if the drying effect of the desiccant is sufficient. There is a menu item which informs you if the humidity inside of the device is OK or if the 30% threshold has been exceeded. In addition, a warning signal will be given after power-up if the humidity is too high. When performing remote data requests of this device a warning will be displayed as well. This message is for your information. The device can still be operated.

Another advantage of the humidity monitoring is that leakages can be detected. If moisture should ingress the desiccant will be saturated very quickly. Thus it becomes apparent that the enclosure is not tight.

If the humidity warning is given you should send the device to the manufacturer for desiccant replacement. If necessary, the desiccant can also be replaced by the user.

44.2 Replacement of the drying agent by the user



We ship the drying agent (desiccant) packed in small airtight bags. The amount per bag is sufficient for exactly one device. Never use any other drying agent.

The same quantity is required for the L-Flame Flame Head as for a PFE Advanced 10/100 Outputs.

Please order the amount that is necessary as soon as the old drying agent became saturated. You may order higher amounts because the shelf life is in principle almost unlimited.

You will find an indicator sheet in the bag. Its purpose is to monitor if the bag is still hermetically sealed. A description how to analyse it can be found printed on the sheet.



Open this screw on the underside of the housing using a size 5 Allen key, remove the plastic seal and place the unit down and allow the desiccant to trickle out. Move the device back and forth so that all residues of the granulate trickle out completely. The used up drying agent can be disposed of as domestic waste or you may want to regenerate it as described below and use it again.



Now you can fill in fresh drying agent. We offer a special cone as an accessory part to make this procedure less difficult. Put the device on an even surface with the filling hole pointing upwards. Then apply the cone. Fill in the new drying agent slowly. If you lift the device on the side the granulate is trickling little by little into the reservoir inside the device. Move the device forth and back so that the granulate is distributed evenly in the reservoir and the full amount of desiccant can be filled in.

Insert the screw with the sealing and fasten the screw hand-tight again. Make sure that the surfaces are clean when doing so.

44.3 How to regenerate the drying agent

Instead of disposing off the old drying agent you may want to regenerate und use it again. This is normally only interesting if the shipment for sending new desiccant is too costly or would take too long.

The best method of regeneration is by using a common baking oven as you will find in every household. Set the temperature to approx. 130 °C. Use upper and lower heat.

Distribute the drying agent evenly as possible on a baking tray. You may regenerate higher amounts, e.g. the drying agent of several devices, at once. As soon as the oven reached the selected temperature, insert the baking tray and close the door of the oven.

With gaining temperature the water of the saturated desiccant evaporates. Now it is important that the humidity is vented almost completely. This is achieved by opening the door of the oven after ten minutes. Please mind the fact that hot and humid air will raise from the oven. Be very careful when opening the door and make sure not to have your face over the door opening. Close the door again after the venting sequence and keep it closed for at least another ten minutes. Repeat this procedure for three or four times until no humidity evaporates and all the crystals of the granulate show an intense orange colour.

Use a pair of heat-resistant gloves and remove the tray from the oven to fill the heated drying agent into a container that can stand the temperature and can be closed airtight. A small glass bottle with a large opening and a sealed cap would be ideally suited. Close the container right after filling in the drying agent. The material can be stored infinitely in an airtight container. If necessary, you may replace the saturated drying agent of a device with regenerated material.

NOTICE 4.2	Filling with heated drying agent Do not fill heated drying agent into the device. The reservoir could be damaged.
--------------------------	---

45 Maintenance and service life of the components

To check the operational reliability, we recommend carrying out a pump test. This can be called up in the menu of the Pump Station.

The devices should be serviced by the manufacturer annually in the case of intensive use and somewhat every two years in the case of low intensity of use.

The following work will be carried out:

- Inspection and, if necessary, replacement of seals and O-rings
- Lubrication of seals
- Individual testing of each magnetic valve on its own
- Inspection and, if necessary, tightening of screws
- Checking and, if necessary, repairing screw locking measures
- Visual inspection of the circuit board and all electrical connections for corrosion or other damages requiring repair
- Replacement of damaged or defective components
- Cleaning of the device if necessary
- Cleaning or replacing the micro filter
- Complete function test including communication test
- Check of the frequency deviation of the radio modules if installed
- Adjusting the ignition electrodes, replacement of electrodes if necessary

Regular maintenance ensures a long service life and provides the basis for reliable and safe operation. In general, it can be assumed that safe operation can no longer be guaranteed after five years without maintenance by the manufacturer or an authorized dealer.

All quick couplers (both sides) generally have a service life of only eight years. Have these parts replaced by the manufacturer before this period has expired.

After 50,000 switching cycles, the magnetic valves should be replaced by the manufacturer.

46 Optimum charging regime and storage conditions for maximum battery life

If the device is used frequently, it is best to basically charge it in the in-between time. It will then always be at your disposal.

If the device is used less frequently, then we recommend charging it for approx. 14 h before each use and for 14 h after each use. During operating breaks, you should recharge the device about every 3-6 months for at least 14 h to compensate for losses due to self-discharge.

As far as the storage conditions are concerned, warm ambient temperatures lead to a drastic shortening of the service life, because the chemical aging processes are then accelerated. This effect already starts from approx. 20°C upwards. If the batteries are exposed to high temperatures for a longer period of time, then the service life may well be shorter than one year. This applies equally to all battery technologies.

Lifetime at different temperatures during long-term exposure:

Temperature	Lifetime in percent	Expected lifetime
20°C	100%	approx. 5 years
30°C	75%	approx. 4 years
40°C	33%	approx. 20 months
50°C	10%	approx. 6 months
60°C	5%	approx. 3 months

We therefore recommend storing the devices in an air-conditioned room in warm regions. Sheds or containers outdoors, which may also be exposed to the sun and are heating up during the day, are the worst possible place for storing the devices for longer periods.

47 Cleaning

The devices are very robust. Please take care that e.g. no burning or hot cinders from firework effects fall onto the device, because this may cause damage to the surfaces.

Ensure that the devices are switched off before you clean them.

Use a piece of cloth that was moistened with water and at the most some dishwashing agent, for cleaning the device. Solvents, strong detergents and abrasives could damage the surfaces.

Keep all electrical contacts and all hydraulic connectors always clean.

Unburned carbon may accumulate at the ignition electrodes. This is absolutely normal and does not impair the function of the device.

If a lot of unburned carbon has accumulated, we recommend to clean the ignition by using a soft brush. Pay attention not to bend the electrodes. In case that the soot cannot be removed this way moisten the brush with brake cleaner. The gap between the tips of the ignition electrodes should approx. 3 mm.

All fuel-carrying components must not be contaminated in order to prevent malfunctions.

48 Warranty

The warranty period is 24 months.

If there is any defect during in this period please pack the device properly and send it to the manufacturer with carriage paid to have it repaired free of charge. Please do not forget to attach a description of the symptoms, which have occurred.

Warranty is excluded if the device was damaged due to wrong usage or excessive stress.

Unauthorized repairs and the use of non-original parts will void all warranty, guarantee and product liability claims with immediate effect.

49 Damages caused by misuse, maloperation, malfunction

Die Geräte wurden ausschließlich zur Erzeugung von Flammeneffekten entwickelt. Jegliche andere Anwendung muss zuvor mit dem Hersteller abgesprochen werden. Für den Fall, dass oben genannte Folgen eintreten sollten, wird eine Haftung nur dann gewährt, wenn die Ursache in unserem Einflussbereich liegt. Die Geräte wurden nach bestem Wissen und Gewissen entwickelt, getestet und gefertigt.

Insbesondere die Einhaltung der Sicherheitsregeln und der in der Betriebsanleitung gegebenen Handhabungsvorschriften ist unbedingte Voraussetzung für jede Anwendung.

Zahlreiche Tests sowie die Praxiserfahrung haben gezeigt, dass die Geräte sehr sicher und zuverlässig arbeiten, selbst wenn diese unter schwierigen Bedingungen eingesetzt werden.

50 Technical data L-Flame Pump Station

Temperature range (excluding fuels)	Transport and storage: -30 to +60°C Operation: -20 to +60°C Optimal storage temperature for longest battery life: +10 to +20°C
Air humidity	10-90% relative humidity, without condensation or moisture condensation due to rain, drizzle, fog, haze, etc. inside the device; The device is not waterproof, it must be protected from damage by water.
Allowable altitudes above sea level	Transport and storage: -500 to 12,500 m Operation: -500 to 3,000 m

Dimensions (LxWxH) and weight:

660 x 402 x 407 mm; 55.0 kg

Power supply and charging concept:

12 V, 39.6 Ah, sealed lead acid type rechargeable battery, L-Flame charger

Supplied accessories, included in delivery of the L-Flame Pump Station:

- 1 L-Flame charger
- 2 Magnetic pens with Lanyard
- 1 Emergency Off Bridge to operate the device without an E-Stop being connected
- 1 Drain hose
- 1 User manual for the L-Flame system

Charging device:

Mains voltage	100-240 VAC, 50-60 Hz, 2.0 A
Charging time	Full charge within 14 h, no danger of overcharging, automatic trickle charge
Dimensions	L-W-H 167 x 67 x 36 mm
Weight	0.62 kg
Temperature range	Transport and storage: -40 to +85°C Operation: -20 to +70°C
Air humidity	Transport and storage: 10-95% rH, not condensing Operation: 20-90% rH, not condensing
Allowable altitudes above sea level	Transport and storage: -500 to 12,500 m Operation: -500 to 2,000 m, temperature derating if exceeded

51 Technical data L-Flame Flame Head

Radio parameters EU version (if Advanced radio module is installed)	<p>Frequency Band: 433.05 - 434.79 MHz Maximum radio-frequency power transmitted: ≤ 10 mW Channel Spacing: 25 kHz Number of radio channels: 70 (433.050 - 434.775 MHz) Modulation: FM narrow band Frequency Shift: ± 3 kHz Duty Cycle: $< 10\%$ Radio equipment class according to 2014/53/EU (RED): 1 Radio equipment type: non-specific short-range device, transmitter and receiver (Transceiver) Receiver Category according to ETSI EN 300 220 V3.1.1: demanded by the application: 3 (lowest performance level), fulfilled by the device: 1 (best performance level); The receiver category indicates how well the device can still receive radio protocols when strong signals are present on frequencies below and above the used frequency (blocking). Receiver Principle: Double superheterodyne Receiver Sensitivity: -119 dBm @ 12 dB SINAD Wave Length: 70 cm Standard antenna included in delivery: Center Frequency: 434 MHz Radiation Pattern: omnidirectional Radiator Length: $\lambda/4$, not coiled Antenna Gain: 0.00 dBd, 2.15 dBi</p>
Radio parameters version for USA and Canada (if Advanced radio module is installed)	<p>Frequency Range: 458 - 462.5 MHz License USA: FCC Part 90, FCC-ID: V9X-LMD401 License Canada: IC 6079A-LMD401 Maximum radio-frequency power transmitted: ≤ 10 mW Channel Spacing: 12.5 kHz Number of radio channels: 360 (458.0000 - 462.5000 MHz) Modulation: FM narrow band Frequency Shift: ± 3 kHz Receiver Principle: Double superheterodyne Receiver Sensitivity: -119 dBm @ 12 dB SINAD Wave Length: 65 cm Standard antenna included in delivery: Center Frequency: 460 MHz Radiation Pattern: omnidirectional Radiator Length: $\lambda/4$, not coiled Antenna Gain: 0.00 dBd, 2.15 dBi</p>
Protocol parameters (if Advanced radio module is installed)	half-duplex, PCM with Manchester coding, Checksum: 40 Bit CRC, data rate approx. 2,500 bps
Temperature range (excluding fuels)	Transport and storage: -30 to $+60^{\circ}\text{C}$ Operation: -20 to $+60^{\circ}\text{C}$
Air humidity	0-100% rH, waterproof and dustproof according to IP65
Allowable altitudes above sea level	Transport and storage: -500 to 12,500 m Operation: -500 to 3,000 m
Ignition	two electrical arcs
Number of electromagnetic valves	2, connected in series
Functional principle of the flame monitoring system	optical

Dimensions (LxWxH) and weight, each without antenna:

235 x 263 x 405 mm; 16.4 kg

Power supply:

The power supply is normally provided by the L-Flame Pump Station.

To operate a device e.g. for programming without Pump Station there are 5V power supplies.

Supplied accessories, included in delivery of the Flame Head:

1 L-Flame nozzle G2.3

The following parts are included if an Advanced wireless module is ordered:

1 standard antenna

1 BNC feedthrough socket to be installed in the housing of the L-Flame Flame Head

1 antenna cable with two BNC connectors to establish the connection between the BNC antenna feedthrough and the Advanced wireless module

52 Accessories

Below is a list of original accessories that can be obtained from the manufacturer or authorized distributors at any time. The device may only be operated with these original accessories. Otherwise, all claims arising from warranty, guarantee and product liability will become void with immediate effect.

Item No.:	Item description:
1932	L-Flame Pump Station
1933	L-Flame Flame Head
10327	L-Flame Refuel Station
10336	L-Flame hose and cables 2m
1934	L-Flame hose and cables 5m
1935	L-Flame hose and cables 10m
1936	L-Flame hose and cables 15
1937	L-Flame hose and cables 25m
1942	L-Flame power cable 2m
10374	L-Flame data cable 5m
1943	L-Flame data cable 10m
10309	L-Flame nozzle G1.3
10311	L-Flame nozzle G2.3
10333	L-Flame nozzle tool
10332	L-Flame drain hose
1311	Magnetic pen
15001	Emergency Off Button (E-Stop switch)
1499	Emergency Off Splitter 8-way
15000	Emergency Off Splitter 16-way
10337	Charging unit L-Flame
1412	Filling cone for desiccant
10339	Mounting plate for L-Flame Flame Head and truss systems
1938	Wireless Advanced module for L-Flame for wireless controlling and programming of the L-Flame (by default EU, version for USA/Canada available for an extra charge)
10213	Extra charge for radio module for USA/Canada
1320	Standard antenna EU
15006	Standard antenna USA/Canada
1341	Antenna extension cable 1m
1342	Antenna extension cable 2m
1345	Antenna extension cable 5m
1343	BNC-BNC adaptor

53 CE marking of the EU version

The EU version of this device is marked with the CE logo:

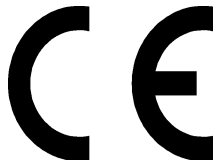

Each device intended for operation in the EU is accompanied by an EU Declaration of Conformity.

54 Address of the manufacturer and contact details for requesting an EU declaration of conformity

Galaxis Showtechnik GmbH
Lohgerberstr. 2
84524 Neuötting
Germany

Tel.: +49 / 8671 / 73411
Fax: +49 / 8671 / 73513

Homepage: www.galaxis-showtechnik.de
E-Mail: info@galaxis-showtechnik.de

Please use these contact details if you want to request an EU declaration of conformity.

Each device intended for operation in the EU is accompanied by an EU Declaration of Conformity.

55 Use of the devices in the USA or Canada

For liability reasons, we first of all prohibit the operation in the USA and Canada in general. Please also see the General Terms and Conditions of Galaxis Showtechnik GmbH.

An operation is only allowed if the written permission from the manufacturer is available. In addition, a liability insurance for these countries must be paid. This is 5% of the value of goods of all purchased items including software.

A paid invoice with this product liability insurance for this is considered as written permission.

Alternatively, a written indemnification of liability can be made by the end customer, which must first be accepted in writing by the manufacturer before the devices may be put into operation in these countries.